

**Grade 6**

**CONTENT BOOKLETS:  
TARGETED SUPPORT**

**Term 1**



# A MESSAGE FROM THE NECT

## NATIONAL EDUCATION COLLABORATION TRUST (NECT)

### Dear Teachers

This learning programme and training is provided by the National Education Collaboration Trust (NECT) on behalf of the Department of Basic Education (DBE)! We hope that this programme provides you with additional skills, methodologies and content knowledge that you can use to teach your learners more effectively.

### What is NECT?

In 2012 our government launched the National Development Plan (NDP) as a way to eliminate poverty and reduce inequality by the year 2030. Improving education is an important goal in the NDP which states that 90% of learners will pass Maths, Science and languages with at least 50% by 2030. This is a very ambitious goal for the DBE to achieve on its own, so the NECT was established in 2015 to assist in improving education.

The NECT has successfully brought together groups of people interested in education so that we can work collaboratively to improve education. These groups include the teacher unions, businesses, religious groups, trusts, foundations and NGOs.

### What are the Learning programmes?

One of the programmes that the NECT implements on behalf of the DBE is the 'District Development Programme'. This programme works directly with district officials, principals, teachers, parents and learners; you are all part of this programme!

The programme began in 2015 with a small group of schools called the Fresh Start Schools (FSS). The FSS helped the DBE trial the NECT Maths, Science and language learning programmes so that they could be improved and used by many more teachers. NECT has already begun this scale-up process in its Provincialisation Programme. The FSS teachers remain part of the programme, and we encourage them to mentor and share their experience with other teachers.

Teachers with more experience using the learning programmes will deepen their knowledge and understanding, while some teachers will be experiencing the learning programmes for the first time.

Let's work together constructively in the spirit of collaboration so that we can help South Africa eliminate poverty and improve education!

[www.nect.org.za](http://www.nect.org.za)



# CONTENTS

TOPIC 1: WHOLE NUMBERS	4
TOPIC 2: COMMON FRACTIONS	19
TOPIC 3: TIME	28
TOPIC 4: PROPERTIES OF 2D SHAPES	35
TOPIC 5: DATA HANDLING	45
TOPIC 6: NUMERIC PATTERNS	54

# TOPIC 1: WHOLE NUMBERS

## INTRODUCTION

- This unit runs for 12 hours.
- This unit is part of the content area 'Numbers, Operations and Relationships'. This content area counts for 50% of the final exam.
- This unit covers whole numbers up to 9 digits.
- The purpose of this section is to develop a deeper sense of number and computational skills and to prepare learners for algebra. New concepts and vocabulary are introduced and built on.

## SEQUENTIAL TEACHING TABLE

INTERMEDIATE PHASE / GRADE 5	GRADE 6	GRADE 7 SENIOR PHASE / FET PHASE
LOOKING BACK	CURRENT	LOOKING FORWARD
<ul style="list-style-type: none"> <li>Order, compare and represent numbers to at least 6-digit numbers</li> <li>Represent odd and even numbers to at least 1 000.</li> <li>Recognize the place value of digits in whole numbers to at least 6 digit numbers.</li> <li>Round off to the nearest 5, 10, 100 and 1 000</li> </ul>	<ul style="list-style-type: none"> <li>Order, compare and represent numbers to at least 9-digit numbers</li> <li>Represent prime numbers to at least 100</li> <li>Recognizing the place value of digits in whole numbers to at least 9-digit numbers</li> <li>Round off to the nearest 5, and powers of 10 up to 1 000 000</li> <li>Using a range of techniques to perform and check written and mental calculations of whole numbers including:               <ul style="list-style-type: none"> <li>estimation</li> <li>building up and breaking down numbers</li> <li>rounding off and compensating</li> <li>using addition and subtraction as inverse operations</li> <li>adding, subtracting in columns</li> </ul> </li> </ul>	<ul style="list-style-type: none"> <li>Revise the following done in Grade 6:               <ul style="list-style-type: none"> <li>Order, compare and represent numbers to at least 9-digit numbers</li> <li>recognize and represent prime numbers to at least 100</li> <li>round off numbers to the nearest 5, 10, 100 or 1 000</li> </ul> </li> <li>Revise the following done in Grade 6:               <ul style="list-style-type: none"> <li>recognize and represent prime numbers to at least 100</li> </ul> </li> <li>Order, compare and represent numbers to at least 9-digit numbers</li> <li>Revise prime numbers to at least 100</li> <li>In the FET Phase:               <ul style="list-style-type: none"> <li>At this stage learners are applying their knowledge on the numbers and operations across all contexts and this is no longer an individual section of mathematical knowledge. The FET phase requires an increasing depth of the knowledge gained in all the previous phases so that application of knowledge can be used to solve problems in a large variety of contexts.</li> </ul> </li> <li>This also is extended into the algebraic concepts covered during the remainder of the senior phase and the FET phase.</li> <li>Number sense is the key to Mathematical Literacy in learners.</li> </ul>



## GLOSSARY OF TERMS

Term	Explanation / Diagram
<b>Whole numbers</b>	The numbers you use to count with. They are the positive integers. A fraction is not a whole number.
<b>Place Value</b>	The value of the digit depends on its position in the number. The same digit can have different values because of its positions in a number. In 12 728, the 2 is in the 'thousands' position, where it has a value of 2 000 and also in the 'tens' position, with a value of 20.
<b>Rounding off</b>	Rounding is writing a number as an approximate. Numbers are rounded up or down to the nearest multiple of 5, 10, 100, 1 000 etc. Numbers with a rounding indicator of 1, 2, 3 or 4 means they are rounded down. Numbers with a rounding indicator of 5, 6, 7, 8 or 9 means they are rounded up. i.e., 24 is rounded down to 20 [rounding indicator is 4]; 88 is rounded up to 90 [rounding indicator is 8].
<b>Digit</b>	There are ten digits, 0, 1, 2, 3, 4, 5, 6, 7, 8 and 9. They are used to build up numbers, for example in the number 502 the digits 5, 0 and 2 are used to build up a number that is worth $500 + 2$ . The zero hold the place for the tens, of which this number does not have any.
<b>Inverse Operations</b>	Inverse operations are opposite (or reverse) operations that undo each other. Addition and subtraction are inverse operations, so that $8 + 9 = 17$ and $17 - 9 = 8$ . Multiplication and division are inverse operations, so that $6 \times 4 = 24$ and $24 \div 4 = 6$ .
<b>Equation</b>	An equation is a mathematical statement in two parts. The expression on the left-hand side and that on the right-hand side are equal in value and are related by means of the = sign.
<b>Terminology in a multiplication equation</b>	factor $\times$ factor = product multiplier $\times$ multiplicand = product e.g. $2 \times 3 = 6$
<b>Terminology in a division equation</b>	Dividend $\div$ Divisor = Quotient e.g. $36 \div 4 = 9$
<b>Order of operation</b>	<b>BODMAS</b> When there are multiple operations in the same mathematical expression there is a particular order: 1. Brackets [ ] 2. Order [exponents and roots] 3. Division and multiplication: work from left to right 4. Addition and subtraction: work from left to right
<b>Estimation</b>	Making a reasonable guess without calculating
<b>Multiples</b>	A multiple is formed when two or more numbers are multiplied by each other/ one another. The product is a multiple of all those numbers and all their combinations, for example $2 \times 3 \times 5 = 30$ , so 30 is a multiple of 2, 3, 5, 6, 10 and 15.



# Topic 1: Whole Numbers

Term	Explanation / Diagram
<b>Factors</b>	The factors of a number are all the numbers that can be divided perfectly into that number [without a remainder]. For example, the factors of 30 are 2, 3, 5, 6, 10 and 15.
<b>Prime Numbers</b>	A prime number has only two factors, namely 1 and itself, for example $17 = 1 \times 17$ . 1 is not a prime number since it has only one factor.
<b>Composite Numbers</b>	A number that has more than two factors e.g. 25 is a composite number because it has more than two factors: 1, 5 and 25
<b>Commutative Property</b>	The order of numbers in addition and multiplication does not matter... $4 + 2 = 6$ and $2 + 4 = 6$ $4 \times 5 = 20$ and $5 \times 4 = 20$ ... but this law does not work for subtraction or division.
<b>Associative Property</b>	Grouping numbers in addition and multiplication... $[7 + 3] + 5 = 15$ or $7 + [3 + 5] = 15$ $[2 \times 3] \times 4 = 24$ or $2 \times [3 \times 4] = 24$ ... but this law does not work for subtraction and division
<b>0 - Additive Property</b>	Adding a zero leaves a number the same. e.g. $8 + 0 = 8$ and $27 + 0 = 27$
<b>1 - Multiplicative Property</b>	Multiplying by one leaves a number unchanged. e.g. $8 \times 1 = 8$ and $27 \times 1 = 27$
<b>Less than</b>	A number that is smaller than another. In an algebraic inequality it is written for example as $13 < 15$ or $12 - 4 < 13 - 4$ .
<b>Greater than</b>	A number that is more than another. In an algebraic inequality it is written for example as $15 > 13$ or $16 - 4 > 13 - 4$ .
<b>Problem-solving</b>	For a long time, problem solving in mathematics has been seen as 'word sums' in which mathematics is used to find the answer. Word sums can also require problem solving but problem solving is more: it requires mathematical thinking to solve a situation for which there is no standard way or method to solve it, than to think logically and reason it out step by step.
<b>Distributive Property</b>	A number that appears before a set of numbers in bracket, is multiplied with all the numbers in the brackets, for example $3(4 + 5) = 3 \times 4 + 3 \times 5$ . This is called the distributive property of multiplication over addition.



## SUMMARY OF KEY CONCEPTS

### Counting in ten thousands and hundred thousands

1. This can be done orally at the start of a lesson.

Count from any number, it does not have to start with multiples of 10. Learners should not be limited to oral counting and should also be encouraged to use counting aids such as:

- number grids
- structured, semi-structured and empty number lines

1) Count in 5's

20		30	35			50	
----	--	----	----	--	--	----	--

2) Count in 10's

	78	88		108		128	
--	----	----	--	-----	--	-----	--

3) Count in 2's

	83		87	89			95
--	----	--	----	----	--	--	----

4) Count in 100's

132	232		432			732	
-----	-----	--	-----	--	--	-----	--

5) Count in 1's

	96		98	99			102
--	----	--	----	----	--	--	-----

6) Count in 10's

113		133	143			173	
-----	--	-----	-----	--	--	-----	--

7) Count in 5's

	55	60		70			85
--	----	----	--	----	--	--	----

8) Count in 100's

248	348		548		748		
-----	-----	--	-----	--	-----	--	--

9) Count in 2's

145		149	151		155		
-----	--	-----	-----	--	-----	--	--

- pictures of objects, especially pictures of large numbers of objects that are presented in a grouped or structured way.



An example of a picture of objects suitable for counting is:

1. How many dots are there? Count in **nines**. Write the answer in the box.

2. How many socks are there? Count in **twos**. Write the answer in the box.

3. How many cubes in total?



- arrays or diagrams of arrays e.g.

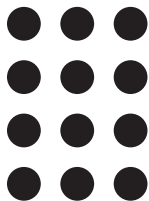

# Topic 1: Whole Numbers

- Count forwards and backwards.



## Teaching Tip:

Using a large number chart can help learners with this task. Also having learners play games that require physical movement such as hopscotch can help to make cognitive connections with counting.

## Skip Count Hopscotch By 10

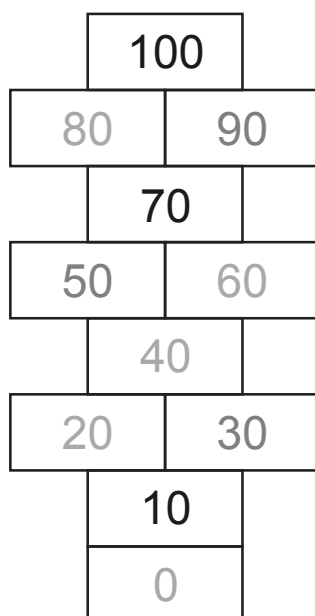

## Numbers up to ten million in words and numerals

### 1. In table form

	TM Ten Millions	M Millions	HT Hundred Thousands	TT Ten Thousands	T Thousands	H Hundreds	T Tens	U Units
Digits	6	5	3	1	4	7	2	8
What the digit means in terms of its position	This stands for 6 millions	This stands for 5 millions	This stands for 2 hundred thousands	This stands for 1 ten thousand	This stands for 4 thousands	This stands for 7 hundreds	This stands for 2 tens	This stands for 8 ones or units
Numeric	60 000 000	5 000 000	30 000	10 000	4 000	700	20	8
How you would say it	Sixty million	Five million	Three hundred thousand	Ten thousand	Four thousand	Seven hundred	Twenty	Eight
What each digit stands for	The digit 6 stands for 60 000 000	The digit 5 stands for 5 000 000	The digit 3 stands for 300 000	The digit 1 stands for 10 000	The digit 4 stands for 4000	The digit 7 stands for 700	The digit 2 stands for 20	The digit 8 stands for 8
The value of the digit	The value of the digit 6 is 60 000 000	The value of the digit 5 is 5 000 000	The value of the digit 3 is 300 000	The value of the digit 1 is 10 000	The value of the digit 4 is 4000	The value of the digit 7 is 700	The value of the digit 2 is 20	The value of the digit 8 is 8

### 2. In Numerals: 65 314 728

### 3. In Words:

Sixty five million, three hundred and fourteen thousand, seven hundred and twenty-eight.

### 4. Expanded Form:

$$65\,000\,000 + 5\,000\,000 + 300\,000 + 10\,000 + 4000 + 700 + 20 + 8$$

### 5. Identify the place and value of each digit in a number up to ten million

65 314 728

The digit 6 is in the ten million place

The digit 5 is in the million place

The digit 3 is in the hundred thousand place

The digit 1 is in the ten thousand place

The digit 4 is in the thousand place

The digit 7 is in the hundred place

The digit 2 is in the tens place

The digit 8 is in the unit /ones place

# Topic 1: Whole Numbers

## Compare numbers within ten million:

1. Smaller than: <

Which number is smaller, 237 981 or 500 600?

When we compare numbers we look at the value of each digit starting from the left.

HT Hundred Thousand	TT Ten Thousand	T Thousand	H Hundred	T Ten	U Units (One)
<b>2</b>	3	7	9	8	1
<b>5</b>	0	0	6	0	0

2 hundred thousands is smaller than 5 hundred thousands. So,  $237\ 981 < 500\ 600$ .

2. Greater than: >

Which number is greater, 712 935 or 712 846?

HT Hundred Thousand	TT Ten Thousand	T Thousand	H Hundred	T Ten	U Units (One)
7	1	2	<b>9</b>	3	5
7	1	2	<b>8</b>	4	6

A table makes it easier to work out which number is bigger/smaller than another.

Work from left to right.

If they are the same, continue to compare until the values of the digits are not the same.

The values of the digits in the hundreds place are not the same.

9 hundred is greater than 8 hundred. So  $712\ 935 > 712\ 846$ .

3. Arrange the numbers from smallest to biggest (ascending order)

324 688, 32 468, 3 246 880

Look at which number has the least digits. If the numbers have the same number of digits, the above method will need to be used.

Answer: 32 468, 324 688, 3 246 880

4. Arrange the numbers from biggest to smallest (descending order)

324 688, 32 468, 3 246 880

Answer: 3 246 880, 324 688, 32 468

Look at which number has the most digits. If the numbers have the same number of digits, the above method will need to be used.

## Rounding off

For rounding with ease, the following steps may be followed:

1. Decide which digit is the last one you need to keep. You will know this because it is the digit in the place you are asked to round off to.
2. Leave it the same if the next digit is less than 5



**Example:** Round 74 to the nearest 10

We want to keep the 7 in the 10s place

The next digit is 4 it is less than 5, so no change is needed to 7

**rounded to 70**

74 gets rounded down

3. Increase it by 1 if the next digit is 5 or higher



**Example:** Round 86 to the nearest 10

We want to keep the 8 in the 10s place

The next digit is 6 which is 5 or more, so increase the 8 by 1 to 9

**rounded to 90**

86 gets rounded up

## Addition and Subtraction

4. Patterns in addition

Learners need to discover patterns so that addition can be calculated in their heads.

This is a life skill, especially when dealing with money or measurement.

Look for pairs of numbers that can give a result of 10, 100 or 1 000



**Example:**  $6 + 5 + 2 + 5 + 4 + 8 = 30$

because  $6 + 4 = 10$

$5 + 5 = 10$

$2 + 8 = 10$

all together  $= 30$



**Example:**  $40 + 30 + 60 + 70 = 200$

because  $40 + 60 = 100$

$30 + 70 = 100$

all together  $= 200$

# Topic 1: Whole Numbers



**Example:**  $100 + 400 + 200 + 600 + 900 + 800 = 3\ 000$   
because  $100 + 900 = 1\ 000$   
 $400 + 600 = 1\ 000$   
 $200 + 800 = 1\ 000$   
all together  $= 3\ 000$

## 2. Adding with 5 digits

### a. Expanded vertical column method

Again this is a good way to calculate quickly. Although most people use calculators this is an important skill to quickly calculate and think on ones feet.

$$\begin{aligned} 37\ 633 &= 30\ 000 + 7\ 000 + 600 + 30 + 3 \\ 50\ 762 &= 50\ 000 + \quad + 700 + 60 + 2 \\ \hline +62\ 873 &= 60\ 000 + 2\ 000 + 800 + 70 + 3 \\ &= 140\ 000 + 9\ 000 + 2\ 100 + 160 + 8 \\ &= (140\ 000) + (9\ 000 + 2\ 100) + (160 + 8) \\ &= 140\ 000 + 11\ 100 + 168 \\ &= 151\ 100 + 168 \\ &= \mathbf{151\ 268} \end{aligned}$$

### b. The traditional method which should be used in Grade 6

$$34\ 305 + 26\ 779 + 884 =$$

$$\begin{array}{r} 34\ 305 \\ 26\ 779 \\ + \quad 884 \\ \hline 62\ 068 \end{array}$$

It is important that learners write the same place values directly underneath each other, for example all units vertically underneath each other, all tens and so on.

## 3. Subtraction with 5 digits:

### a. Subtraction using the expanded vertical column method

$$\begin{aligned} 38\ 342 &= 30\ 000 + 8000 + 300 + 40 + 2 \\ - 3\ 231 &= \underline{\quad\quad\quad} - 3000 - 200 - 30 - 1 \\ &= 30\ 000 + 5000 + 100 + 10 + 1 \\ &= 35\ 111 \end{aligned}$$



- b. The traditional method or the standard algorithm of subtraction that is used in Grade 6

$$\begin{array}{r}
 78 \ 11 \ 8 \ 67 \ 134 \ 13 \\
 - 6 \ 3 \ 4 \ 6 \ 8 \ 4 \\
 \hline
 1 \ 8 \ 4 \ 0 \ 5 \ 9
 \end{array}$$

Again remind the learners to set out their calculation methodically, as it helps to avoid mistakes.

### 3. Inverse Operations

Remember that addition and subtraction can be used to check each other.

$$12 + 15 = 27 \text{ so therefore,}$$

$$27 - 15 = 12 \text{ OR } 27 - 12 = 15$$

### Order of Operations: BODMAS

Work from left to right

B	O	M D	S A
B	O	D M	A S

<b>Brackets</b>	<b>Order</b> x	<b>Division / Multiplication</b>	<b>Addition / Subtraction</b>
	(powers and roots)	or	or
		<b>Multiplication / Division</b>	<b>Subtraction / Addition</b>
( )	x (2 <sup>2</sup> )	÷ x or x ÷	+ - or - +

1. Perform the operation in brackets first.

$$6 \times (5 + 3) = 6 \times 8 = 48$$

2. Simplify any numbers in exponential- or root form.

$$3 + 5^2 - 16 = 3 + 25 - 16 = 12$$

3. Replace the word "of" with a x sign and multiply or divide from left to right.

$$4 + \frac{1}{3} \text{ of } 9 \times 8 \div 2 = 4 + 3 \times 8 \div 2 = 4 + 24 \div 2 = 4 + 12 = 16$$

4. Do any remaining addition and subtraction from left to right.

$$4 + 13 - 5 - 2 = 10$$

# Topic 1: Whole Numbers

## Multiples

Multiples are the product of two numbers.



1. To find the multiples of a given number:

**Example:** Find the multiples of 3.

$$3 \times 1 = 3$$

$$3 \times 2 = 6$$

$$3 \times 3 = 9$$

$$3 \times 4 = 12$$

The multiples of 3 are: 3, 6, 9, 12,...

To indicate that the list goes on, we add ...



2. Find the first five multiples of 2.

**Example:**

$$2 \times 1 = 2$$

$$2 \times 2 = 4$$

$$2 \times 3 = 6$$

$$2 \times 4 = 8$$

$$2 \times 5 = 10$$

The first five multiples of 2 are: 2, 4, 6, 8, 10. To indicate that the list is complete, we end the list with full stop.

## Factors



These are the numbers which make a product when they are multiplied.

**Example:** Find the factors of 20

Think: which numbers can be multiplied to make 20?

$$1 \times 20 = 20$$

$$2 \times 10 = 20$$

$$4 \times 5 = 20$$

The factors of 20 are: 1, 2, 4, 5, 10 and 20.



## RESOURCES

### PRIME NUMBERS

1	2	3	4	5	6	7	8	9	10
11	12	13	14	15	16	17	18	19	20
21	22	23	24	25	26	27	28	29	30
31	32	33	34	35	36	37	38	39	40
41	42	43	44	45	46	47	48	49	50
51	52	53	54	55	56	57	58	59	60
61	62	63	64	65	66	67	68	69	70
71	72	73	74	75	76	77	78	79	80
81	82	83	84	85	86	87	88	89	90
91	92	93	94	95	96	97	98	99	100

### COMPOSITE NUMBERS

1	2	3	4	5	6	7	8	9	10
11	12	13	14	15	16	17	18	19	20
21	22	23	24	25	26	27	28	29	30
31	32	33	34	35	36	37	38	39	40
41	42	43	44	45	46	47	48	49	50
51	52	53	54	55	56	57	58	59	60
61	62	63	64	65	66	67	68	69	70
71	72	73	74	75	76	77	78	79	80
81	82	83	84	85	86	87	88	89	90
91	92	93	94	95	96	97	98	99	100

# Topic 1: Whole Numbers

Below are some situations described in word form. The table is a guide of how to write the word problem in a number sentence.

<b>PROBLEM-SOLVING TYPES</b>		
<b>JOINING PROBLEMS</b>		
Join (result unknown) $6 + 3 = \underline{\quad}$	Join (Change Unknown) $4 + \underline{\quad} = 7$	Join (start unknown) $\underline{\quad} + 4 = 6$
Mrs Tshabalala had 6 cookies. Sandile gave her 3 more. How many cookies does Mrs Tshabalala have now?	Mrs Tshabalala had 4 cookies. Sandile gave her some more. Then, Mrs Tshabalala had 7 cookies. How many cookies did Sandile give Mrs Tshabalala?	Mrs Tshabalala had some cookies. Sandile gave her 4 more cookies. Then, she has 6 cookies. How many cookies did Mrs Tshabalala have to start with?
<b>SEPARATING PROBLEMS</b>		
Separate (result unknown) $7 - 4 = \underline{\quad}$	Separate (change unknown) $5 - \underline{\quad} = 1$	Separate (start unknown) $\underline{\quad} - 4 = 4$
Mrs Tshabalala had 7 cookies. She gave Sandile 4 of them. How many cookies did Mrs Tshabalala have left?	Mrs Tshabalala had 5 cookies. Mrs Tshabalala gave some to Sandile. Then, Mrs Tshabalala had 1 cookie left. How many cookies did Mrs Tshabalala give Sandile?	Mrs Tshabalala had some cookies. She gave her 4 to Sandile. Then, she had 4 cookies left. How many cookies did Mrs Tshabalala have to start with?
<b>PART - PART - WHOLE PROBLEMS</b>		
Part - Part - Whole (whole unknown) $6 + 3 = \underline{\quad}$		Part - Part - Whole (part unknown) $7 - 4 = \underline{\quad}$ or $4 + \underline{\quad} = 7$
Mrs Tshabalala had 6 blue cookies and three yellow cookies. How many cookies did Mrs Tshabalala have altogether?		Mrs Tshabalala had 7 cookies. 4 were blue and the rest were yellow. How many cookies did Mrs Tshabalala have altogether?
<b>COMPARING PROBLEMS</b>		
Compare (difference unknown) $5 - 3 = \underline{\quad}$ or $3 + \underline{\quad} = 5$	Compare (quantity unknown) $3 + 2 = \underline{\quad}$	
Mrs Tshabalala had 5 cookies. Sandile had 3 cookies. How many more cookies did Mrs Tshabalala have than Sandile?	Mrs Tshabalala had 3 cookies. Sandile had 2 cookies more than Mrs Tshabalala. How many more cookies did Sandile have?	
<b>PROBLEM-SOLVING TYPES</b>		
<b>MULTIPLYING AND DIVIDING PROBLEMS</b>		
<b>MULTIPLICATION</b> $3 \times 3 = \underline{\quad}$	<b>MEASUREMENT DIVISION</b> $9 \div 3 = \underline{\quad}$	<b>PARTITIVE DIVISION</b> $12 \div 3 = \underline{\quad}$
Mrs Tshabalala had 3 piles of cookies. There were 3 cookies in each pile. How many cookies did Mrs Tshabalala have?	Mrs Tshabalala had 9 cookies. She put 3 cookies in each box. How many boxes did she need?	Mrs Tshabalala had 12 cookies. She wanted to give them to 3 friends. How many cookies did each friend get?

# TOPIC 2: COMMON FRACTIONS

## INTRODUCTION

- This unit runs for 10 hours.
- This unit is part of the content area 'Numbers, Operations and Relationships', an area which counts for 50% of the final exam.
- The unit covers whole numbers and part numbers, i.e. common fractions.
- Addition and subtraction of fractions with different denominators and mixed numbers are now introduced.

## SEQUENTIAL TEACHING TABLE

INTERMEDIATE PHASE / GRADE 5	GRADE 6	GRADE 7 SENIOR PHASE / FET PHASE
LOOKING BACK	CURRENT	LOOKING FORWARD
<ul style="list-style-type: none"> <li>Describing and ordering fractions:               <ul style="list-style-type: none"> <li>Count forwards and backwards in fractions</li> <li>Compare and order common fractions to at least twelfths</li> </ul> </li> <li>Calculations with fractions:               <ul style="list-style-type: none"> <li>Addition and subtraction of common fractions with the same denominators</li> <li>Addition and subtraction of mixed numbers</li> <li>Fractions of whole numbers which result in whole numbers</li> <li>Recognize, describe and use the equivalence of division and fractions</li> <li>Solving problems</li> <li>Solve problems in contexts involving common fractions, including grouping and sharing</li> </ul> </li> </ul>	<ul style="list-style-type: none"> <li>Describing and ordering fractions:</li> <li>Compare and order common fractions, including tenths and hundredths</li> <li>Calculations with fractions:               <ul style="list-style-type: none"> <li>Addition and subtraction of common fractions in which one denominator is a multiple of another</li> <li>Addition and subtraction of mixed numbers</li> <li>Fractions of whole numbers</li> </ul> </li> <li>Solving problems               <ul style="list-style-type: none"> <li>Solve problems in contexts involving common fractions, including grouping and sharing</li> </ul> </li> <li>Percentages               <ul style="list-style-type: none"> <li>Find percentages of whole numbers</li> </ul> </li> <li>Equivalent forms:               <ul style="list-style-type: none"> <li>Recognize and use equivalent forms of common fractions with 1-digit or 2Digit denominators [fractions in which one denominator is a multiple of another]</li> </ul> </li> <li>Recognize equivalence between common fraction and decimal fraction forms of the same number</li> <li>Recognize equivalence between common fraction, decimal fraction and percentage forms of the same number</li> </ul>	<ul style="list-style-type: none"> <li>Describing and ordering fractions:</li> <li>Compare and order common fractions with different denominators [halves; thirds; quarters; fifths; sixths; sevenths; eighths]</li> <li>Describe and compare common fractions in diagram form</li> <li>Calculations with fractions:               <ul style="list-style-type: none"> <li>Addition of common fractions with the same denominators</li> </ul> </li> <li>Recognize, describe and use the equivalence of division and fractions</li> <li>Solving problems</li> <li>Solve problems in contexts involving fractions, including grouping and equal sharing</li> <li>Equivalent forms:               <ul style="list-style-type: none"> <li>Recognize and use equivalent forms of common fractions [fractions in which one denominator is a multiple of another]</li> </ul> </li> </ul>



## GLOSSARY OF TERMS

Term	Explanation / Diagram
<b>Tenths</b>	As a common fraction, a tenth/tenths are a part or parts of a whole number where the whole has been subdivided into ten parts. It is written in the form of a numerator above a fraction line, indication the number of tenths and a denominator 10 under the fraction line. In decimal fraction form, the number of tenths is written in the first place after the decimal point.
<b>Hundredths</b>	As a common fraction, a hundredth/hundredths are a part or parts of a whole number where the whole has been subdivided into hundred parts. It is written in the form of a numerator above a fraction line, indication the number of hundredths and a denominator 100 under the fraction line. In decimal fraction form, the number of hundredths is written in the second place after the decimal point.
<b>Thousandths</b>	As a common fraction, a thousandth/thousandths are a part or parts of a whole number where the whole has been subdivided into thousand parts. It is written in the form of a numerator above a fraction line, indication the number of thousandths and a denominator 1 000 under the fraction line. In decimal fraction form, the number of thousandths is written in the third place after the decimal point.
<b>Fraction</b>	A whole divided into a desired number of parts and then representing a necessary number of parts as the numerator where the total number of parts would be the denominator
<b>Mixed Fraction</b>	A number with a whole number and a fraction.
<b>Proper Fractions</b>	A fraction where the numerator is smaller than the denominator.
<b>Improper Fractions</b>	A fraction where the numerator is bigger than the denominator. The term is not used in the CAPS document.
<b>Like Denominators</b>	The denominators of the fractions are the same.
<b>Unlike Denominators</b>	The denominators of the fractions are not the same.
<b>Equivalent Fractions</b>	Equivalent fractions have the same value. One third of a packet of oranges of 12 is four and that is exactly the same as two sixths of the packet, which is also 4.
<b>Simplest Form</b>	A fraction in its most basic form, for example the most basic, or simplest form of four eighths is a half.



## SUMMARY OF KEY CONCEPTS

### Fractions:

1. A fraction is part of a whole.
2. A table like this one (sometimes called a fraction wall) can be used to explain fractions.

1 Whole							
$\frac{1}{2}$				$\frac{1}{2}$			
$\frac{1}{4}$		$\frac{1}{4}$		$\frac{1}{4}$		$\frac{1}{4}$	
$\frac{1}{6}$	$\frac{1}{6}$	$\frac{1}{6}$	$\frac{1}{6}$	$\frac{1}{6}$	$\frac{1}{6}$	$\frac{1}{6}$	$\frac{1}{6}$
$\frac{1}{12}$	$\frac{1}{12}$	$\frac{1}{12}$	$\frac{1}{12}$	$\frac{1}{12}$	$\frac{1}{12}$	$\frac{1}{12}$	$\frac{1}{12}$

### Ordering Fractions

To order fractions means to compare them to find which are larger or smaller. In order to do this, we need to use our knowledge of equivalent fractions and make the denominators equal.



#### Example:

$$\frac{2}{10} * \frac{2}{100} \left( \frac{2}{10} = \frac{20}{100} \text{ the denominators must be the same} \right)$$

This means  $\frac{2}{10}$  is greater than  $\frac{2}{100}$  ( $\frac{2}{10} > \frac{2}{100}$ )



## Addition and Subtraction

3. Addition with the same denominator:

$$\frac{2}{5} + \frac{1}{5} = \frac{3}{5}$$

With a sum like this copy the denominator.

Then add the numerators and put them over the denominator.

If the answer is an improper fraction you need to write it as a mixed number in its simplest form.

$$\frac{2}{5} + \frac{4}{5} = \frac{6}{5}$$

... as the answer is an improper fraction, you need to write it as a mixed number.

The fraction must be in the simplest form.

$$= 1\frac{1}{5} \text{ because } \dots \frac{5}{5} + \frac{1}{5} = \frac{6}{5} \dots \frac{5}{5} = 1 \dots \text{any number over itself} = 1$$

2. Addition with different denominators that have common multiples:

$$\frac{1}{3} + \frac{1}{6} \quad \frac{1}{3} \text{ and } \frac{1}{6} \text{ do not have the same denominator}$$

$$= \frac{2}{6} + \frac{1}{6} \quad \text{Change } \frac{1}{3} \text{ into sixths by multiplying both the numerator and denominator by 2. This will ensure an equivalent fraction to } \frac{1}{3}$$

$$= \frac{3}{6} \quad \frac{1 \times 2}{3 \times 2} = \frac{2}{6}$$

$$= \frac{1}{2}$$

Check that the answer is in its simplest form

3. Subtraction with the same denominator

$$= \frac{2}{6} - \frac{1}{6}$$

$$= \frac{1}{6}$$

## Topic 2: Common Fractions

5. Addition with different denominators that have common multiples:

$$\begin{aligned} & \frac{1}{3} - \frac{1}{6} \\ &= \frac{2}{6} - \frac{1}{6} \\ &= \frac{1}{6} \end{aligned}$$

### Addition and subtraction of mixed numbers

To add and subtract mixed numbers, you first need to convert a mixed number to an improper fraction.

1. To convert a mixed number to an improper fraction.

$$2\frac{1}{3} = \frac{7}{3}$$

First: multiply the whole number with the denominator (in this case  $2 \times 3$ )

Next: add the answer from the previous step to the numerator (in this case  $6+1$ )

Finally: Place this number over the original denominator  $\frac{7}{3}$

2. Addition with mixed numbers:

$$\begin{aligned} & 1\frac{5}{6} + \frac{2}{3} \\ &= \frac{11}{6} + \frac{5}{3} \quad (\text{convert to an improper fraction}) \\ &= \frac{11}{6} + \frac{10}{6} \quad (\text{bring them to the same denominator}) \\ &= \frac{21}{6} \quad (\text{add}) \\ &= 3\frac{3}{6} \quad (\text{convert the improper fraction to a mixed number}) \\ &= 3\frac{1}{2} \quad (\text{write in simplest form where necessary}) \end{aligned}$$

4. Subtraction with mixed numbers:

$$\begin{aligned} & 1\frac{5}{6} - 1\frac{2}{3} \\ &= \frac{11}{6} - \frac{5}{3} && \text{(convert to an improper fraction)} \\ &= \frac{11}{6} - \frac{10}{6} && \text{(bring them to the same denominator)} \\ &= \frac{1}{6} && \text{(subtract)} \end{aligned}$$

Answers must always be in the simplest form.

### Fractions of a Quantity

(The quantity will always be a whole number)

- $\frac{1}{2}$  of 8 = 4      ( $\frac{1}{2} \times 8 = 4$ )
- $\frac{3}{4}$  of 12 = 9      (first find  $\frac{1}{4}$  of 12 = 3; now multiply this by the numerator:  $3 \times 3 = 9$ )

### How to make Equivalent Fractions

To find equivalent fractions do the same operation to the numerator and the denominator.

$$\frac{1}{2} = \frac{2}{4} = \frac{3}{6} = \frac{4}{8}$$

## Topic 2: Common Fractions

1. To get from  $\frac{1}{2}$  to  $\frac{2}{4}$  you multiply the numerator and the denominator by the same number.

$$\frac{1}{2} \times \frac{2}{2} = \frac{2}{4}$$

2. To get from  $\frac{4}{8}$  to  $\frac{1}{2}$  you divide the numerator and the denominator by the same number.

### Fractions to Decimals to Percentage

These are dealt with later in the year, when learners need to convert from fractions to decimals to percentages. However, this term learners are introduced to the relationship between the three fractional forms and should understand the following list.

Percent	Decimal	Fraction in simplest form	Percent	Decimal	Fraction in simplest form
1%	0,01	$\frac{1}{100}$	<b>100%</b>	<b>1%</b>	$\frac{100}{100} = \frac{1}{1}$
5%	0,05	$\frac{1}{20}$	125%	1,25	$\frac{5}{4} = 1\frac{1}{4}$
10%	0,1	$\frac{1}{10}$	150%	1,5	$\frac{3}{2} = 1\frac{1}{2}$
$12\frac{1}{2}\%$	0,125	$\frac{1}{8}$	200%	2	$\frac{200}{100} = \frac{2}{1} = 2$
20%	0,2	$\frac{1}{5}$			
25%	0,25	$\frac{1}{4}$			
$33\frac{1}{3}\%$	0,333	$\frac{1}{3}$			
50%	0,5	$\frac{1}{2}$			
75%	0,75	$\frac{3}{4}$			
80%	0,8	$\frac{4}{5}$			
90%	0,9	$\frac{9}{10}$			
99%	0,99	$\frac{99}{100}$			



## RESOURCES

1 Whole							
$\frac{1}{2}$				$\frac{1}{2}$			
$\frac{1}{4}$		$\frac{1}{4}$		$\frac{1}{4}$		$\frac{1}{4}$	
$\frac{1}{6}$	$\frac{1}{6}$	$\frac{1}{6}$	$\frac{1}{6}$	$\frac{1}{6}$	$\frac{1}{6}$	$\frac{1}{6}$	$\frac{1}{6}$
$\frac{1}{12}$	$\frac{1}{12}$	$\frac{1}{12}$	$\frac{1}{12}$	$\frac{1}{12}$	$\frac{1}{12}$	$\frac{1}{12}$	$\frac{1}{12}$

1 Whole															
$\frac{1}{2}$								$\frac{1}{2}$							
$\frac{1}{4}$				$\frac{1}{4}$				$\frac{1}{4}$				$\frac{1}{4}$			
$\frac{1}{8}$	$\frac{1}{8}$	$\frac{1}{8}$	$\frac{1}{8}$	$\frac{1}{8}$	$\frac{1}{8}$	$\frac{1}{8}$	$\frac{1}{8}$	$\frac{1}{8}$	$\frac{1}{8}$	$\frac{1}{8}$	$\frac{1}{8}$	$\frac{1}{8}$	$\frac{1}{8}$	$\frac{1}{8}$	$\frac{1}{8}$
$\frac{1}{16}$	$\frac{1}{16}$	$\frac{1}{16}$	$\frac{1}{16}$	$\frac{1}{16}$	$\frac{1}{16}$	$\frac{1}{16}$	$\frac{1}{16}$	$\frac{1}{16}$	$\frac{1}{16}$	$\frac{1}{16}$	$\frac{1}{16}$	$\frac{1}{16}$	$\frac{1}{16}$	$\frac{1}{16}$	$\frac{1}{16}$

1 Whole											
$\frac{1}{2}$						$\frac{1}{2}$					
$\frac{1}{4}$			$\frac{1}{4}$			$\frac{1}{4}$			$\frac{1}{4}$		
$\frac{1}{10}$	$\frac{1}{10}$	$\frac{1}{10}$	$\frac{1}{10}$	$\frac{1}{10}$	$\frac{1}{10}$	$\frac{1}{10}$	$\frac{1}{10}$	$\frac{1}{10}$	$\frac{1}{10}$	$\frac{1}{10}$	$\frac{1}{10}$
$\frac{1}{5}$		$\frac{1}{5}$		$\frac{1}{5}$		$\frac{1}{5}$		$\frac{1}{5}$			

1 Whole								
$\frac{1}{3}$			$\frac{1}{3}$			$\frac{1}{3}$		
$\frac{1}{9}$	$\frac{1}{9}$	$\frac{1}{9}$	$\frac{1}{9}$	$\frac{1}{9}$	$\frac{1}{9}$	$\frac{1}{9}$	$\frac{1}{9}$	$\frac{1}{9}$

# TOPIC 3: TIME

## INTRODUCTION

- This unit runs for 4 hours.
- This unit is part of the content area 'Time', an area which counts for 15% of the final exam.
- Learners need to understand different ways of telling time, calculate time intervals and read calendars and timetables as part of daily life.
- The purpose of this unit is to develop the concept of time, build and introduce new vocabulary.

## SEQUENTIAL TEACHING TABLE

INTERMEDIATE PHASE / GRADE 5	GRADE 6	GRADE 7 SENIOR PHASE / FET PHASE
LOOKING BACK	CURRENT	LOOKING FORWARD
<ul style="list-style-type: none"> <li>• Reading time and time instruments</li> <li>• Read, tell and write time in 12-hour and 24-hour formats on both analogue and digital instruments in               <ul style="list-style-type: none"> <li>• hours</li> <li>• minutes</li> <li>• seconds</li> </ul> </li> <li>• Instruments include clocks and watches</li> <li>• Reading calendars</li> </ul> <p>Calculations and problem solving time include:</p> <ul style="list-style-type: none"> <li>• calculation of time intervals where time is given in various formats [seconds, minutes, hours etc]</li> <li>• History of time</li> <li>• Know some ways in which time was measured and represented in the past</li> </ul>	<ul style="list-style-type: none"> <li>• Reading time and time instruments</li> <li>• Read, tell and write time in 12-hour and 24-hour formats on both analogue and digital instruments in               <ul style="list-style-type: none"> <li>• hours</li> <li>• minutes</li> <li>• seconds</li> </ul> </li> <li>• Instruments include clocks, watches and stopwatches</li> <li>• Reading calendars</li> <li>• Calculations and problem solving time include problems in contexts involving time</li> <li>• Calculation of time intervals where time is given in               <ul style="list-style-type: none"> <li>• seconds and/or minutes</li> <li>• minutes and/or hours</li> <li>• hours and/or days</li> <li>• days, weeks and/or months</li> <li>• years and/or decades</li> </ul> </li> <li>• History of time</li> <li>• Know some ways in which time was measured and represented in the past</li> </ul>	<ul style="list-style-type: none"> <li>• Reading time and time instruments</li> <li>• Read, tell and write time in 12-hour and 24-hour formats on both analogue and digital instruments in               <ul style="list-style-type: none"> <li>• hours</li> <li>• minutes</li> <li>• seconds</li> </ul> </li> <li>• Instruments include clocks, watches and stopwatches</li> <li>• Reading calendars</li> <li>• Calculations and problem solving time include problems in contexts involving time</li> <li>• Reading time zone maps and calculating time differences based on time zones</li> <li>• Calculation of time intervals where time is given in               <ul style="list-style-type: none"> <li>• seconds and/or minutes</li> <li>• minutes and/or hours</li> <li>• hours and/or days</li> <li>• days, weeks and/or months</li> <li>• years and/or decades</li> <li>• centuries, decades and/or years</li> </ul> </li> <li>• History of time</li> <li>• Know some ways in which time was measured and represented in the past.</li> </ul>



## GLOSSARY OF TERMS

Term	Explanation / Diagram
<b>Digital (24 hour clock)</b>	This is a type of clock that displays the time digitally in numerals.
<b>Analogue (12 hour clock)</b>	<p>This clock has a face and two hands, the short one for hours and the long one for minutes. The hands move in a circle [clockwise] to point to the time.</p> <p>The twelve hours are indicated by numbers, but the sixty minutes are markings only. Any reading is done in terms of the minutes and the hours. It is not possible to see whether it is before, or after noon on a twelve-hour clock. The cycle repeats every twelve hours, meaning that the exact same image is seen twice during a 24-hour period [a day]. Some analogue clocks have a third [normally red] hand that moves fast to indicate seconds.</p>
<b>Calendar</b>	A chart or pages showing the days, weeks and months of a specific year – which vary for each consecutive year.
<b>Time zones</b>	A time zone is a region of the globe that keeps to a standard time. The globe is divided in 24 "slices" running from north to south, each measuring about 15° and representing one hour difference from the previous "slice". The Greenwich Meridian separates east from west and the counting starts there. When moving in an eastern direction, the time becomes one hour earlier, and moving in a western direction, the time becomes one hour later.
<b>Greenwich Meridian</b>	The Greenwich Meridian separates east from west in the same way that the equator separates north from south. It is linked with Greenwich Mean Time: it also sits at the center of our system of time zones.
<b>Sun dial</b>	A sundial is a device that tells the time of day when there is sunlight by the position of the sun in the sky. It consists of a flat plate [the dial] and a gnomon which casts a shadow onto the dial. As the sun appears to move across the sky, the shadow aligns with different hour-lines, which are marked on the dial to indicate the time of day.
<b>Stopwatch</b>	<p>A stopwatch is used to measure an exact duration of time that is taken to do something [such as to time a race].</p> <p>It can be pressed at the moment the event starts and pressed again when the event ends, so that the duration of the event is measured and one can read it off the display.</p>





## SUMMARY OF KEY CONCEPTS

### Time

60 seconds (s) = 1 minute (m)

60 minutes = 1 hour (h)

24 hours = 1 day (d)

7 days = 1 week (wk)

### Calendar

12 months = 1 year (yr)

52 weeks = 1 year (yr)

10 years = 1 decade (DEC)

100 years = 1 century (C)

### Conversions

Break up hours and minutes, months and years, hours and days to work out a variety of times.

1. How many hours and minutes are there in 158 minutes?  
 $158 \text{ minutes} = 120 \text{ minutes} + 38 \text{ minutes} = 2\text{h } 38 \text{ minutes}$
2. How many years and months are there in 39 months?  
 $39 \text{ months} = 36 \text{ months} + 3 \text{ months} = 3 \text{ years and } 3 \text{ months}$
3. How many hours are there in 6 days and 9 hours?  
 $6 \text{ days and } 9 \text{ hours} = (6 \times 24) \text{ hours} + 9 \text{ hours} = 144 \text{ hours} + 9 \text{ hours} = 153 \text{ hours}$

# Topic 3: Time

## 24 hour clock

In today's world both analogue and digital clocks are used. Although digital clocks show time in 24 hours, we still tend to talk in 12 hours. We also do not say 1 AM/PM, but speak of 1 in the morning or 1 in the afternoon. However, more and more, time is written using the 24-hour clock.

The following table shows the time both in the 24-hour and 12-hour format.

On the hour		10 minutes past	
24 Hour Clock	AM /PM	24 Hour Clock	AM /PM
0:00	12:00 Midnight	0:10	12:10 AM
1:00	1:00 AM	1:10	1:10 AM
2:00	2:00 AM	2:10	2:10 AM
3:00	3:00 AM	3:10	3:10 AM
4:00	4:00 AM	4:10	4:10 AM
5:00	5:00 AM	5:10	5:10 AM
6:00	6:00 AM	6:10	6:10 AM
7:00	7:00 AM	7:10	7:10 AM
8:00	8:00 AM	8:10	8:10 AM
9:00	9:00 AM	9:10	9:10 AM
10:00	10:00 AM	10:10	10:10 AM
11:00	11:00 AM	11:10	11:10 AM
12:00	12:00 Noon	12:10	12:10 PM
13:00	1:00 PM	13:10	1:10 PM
14:00	2:00 PM	14:10	2:10 PM
15:00	3:00 PM	15:10	3:10 PM
16:00	4:00 PM	16:10	4:10 PM
17:00	5:00 PM	17:10	5:10 PM
18:00	6:00 PM	18:10	6:10 PM
19:00	7:00 PM	19:10	7:10 PM
20:00	8:00 PM	20:10	8:10 PM
21:00	9:00 PM	21:10	9:10 PM
22:00	10:00 PM	22:10	10:10 PM
23:00	11:00 PM	23:10	11:10 PM

## Time Zones

The world is divided into 24 hour time zones. The Greenwich Meridian divides the time zones into east and west.

On the map below, the Greenwich Meridian runs in a north-south direction between the regions marked Z and A. When we move to the right-hand side which is an eastern direction, each time zone becomes one hour earlier. Note that there is no J marking and the markings go up to M (12 zones). If we move from the Greenwich Meridian in a western direction to the left, we find Z and N to Y in a reverse order. Each zone represents one hour later than the time on the meridian.

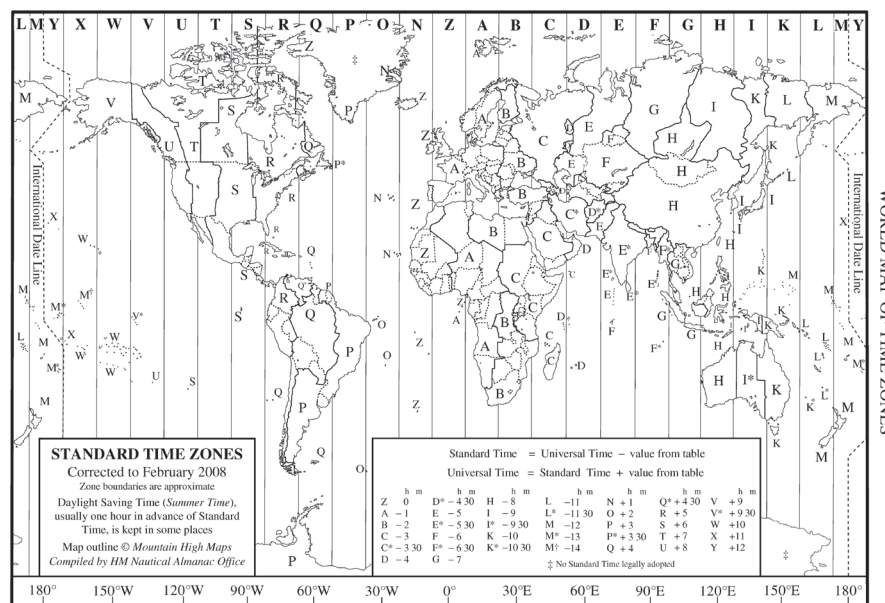

## Working with a calendar

Here is a way to help learners remember how many days in each month.

1. Make hands into fists and look down at them.
2. Months on top of the knuckles have 31 days.
3. Months between the knuckles have 30 days.
4. February is different – it has 28 days in a normal year and 29 days in a leap year, which happens every 4 years.

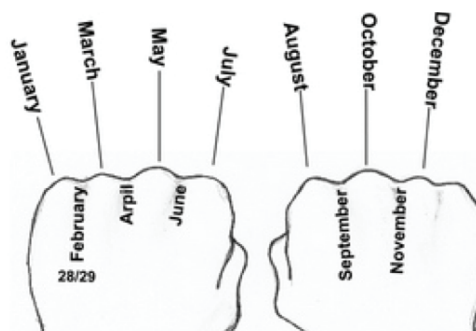

# Topic 3: Time

## History of Time

The Western or Christian calendar is counted from the year Jesus Christ was born. People who use the Christian Calendar divide the years into the time Before Christ was born (BC) and the time after his birth (AD) Anno Dominus.

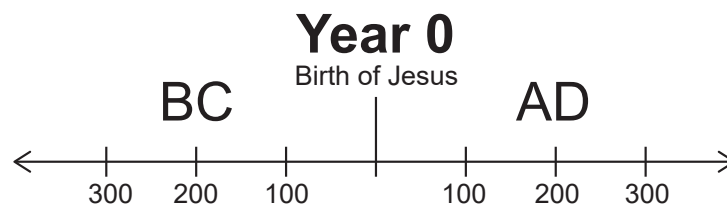

The year 300BC means 300 years before Christ was born.

The year AD 2016 means 2016 years after Christ was born.

This is just one of a number of systems people use around the world.

It is the one used in South Africa.

On a day-to-day basis, people of the ancient world used what they had around them to divide the day into parts. One way of telling the time long ago was to use a sun-stick or a sundial. The Ancient Egyptians used this system by using shadows cast by the sun to tell the time during the day.

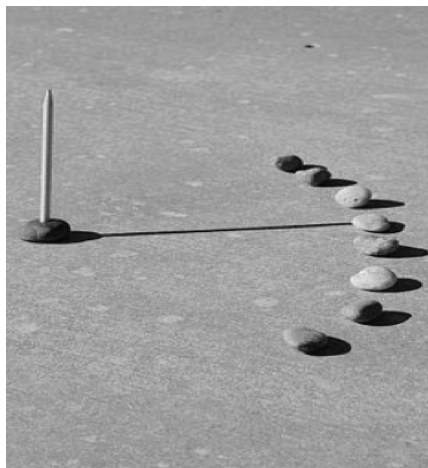

The Ancient Romans took this a step further and used a sundial, which was more accurate.

# TOPIC 4: PROPERTIES OF 2D SHAPES

## INTRODUCTION

- This unit runs for 8 hours.
- Properties of 2D Shapes, is part of the content area Shape and Space. This counts for 15% of the final exam.
- The unit covers the concept of 2D shapes, which form the basis of geometry. Learners need to understand the characteristics of the shapes and be able to distinguish them.
- The purpose of this section is to develop skills to apply to daily life and to develop geometric drawing. New concepts and vocabulary are introduced in Grade 6.

# Topic 4: Properties of 2D Shapes

## SEQUENTIAL TEACHING TABLE

INTERMEDIATE PHASE / GRADE 5	GRADE 6	GRADE 7 SENIOR PHASE / FET PHASE
LOOKING BACK	CURRENT	LOOKING FORWARD
<ul style="list-style-type: none"> <li>• Recognize, visualize and name 2D shapes in the environment and geometric setting, focusing on regular and irregular polygons - triangles, squares, rectangles, other quadrilaterals.               <ul style="list-style-type: none"> <li>• pentagons, hexagons, heptagons circles</li> </ul> </li> <li>• Similarities and differences between squares and rectangles</li> <li>• Characteristics of shapes</li> <li>• Describe, sort and compare 2D shapes in terms of               <ul style="list-style-type: none"> <li>• straight and curved sides</li> <li>• number of sides</li> <li>• lengths of sides</li> <li>• angles in shapes, limited to right angles</li> <li>• angles smaller than right angles</li> <li>• angles greater than right angles</li> </ul> </li> <li>• Draw 2D shapes on grid paper</li> <li>• Recognize and describe angles in 2D shapes:               <ul style="list-style-type: none"> <li>• right angles</li> <li>• angles smaller than right angles</li> <li>• angles greater than right angles</li> </ul> </li> </ul>	<ul style="list-style-type: none"> <li>• Recognize, visualize and name 2D shapes in the environment and geometric settings, focusing on               <ul style="list-style-type: none"> <li>• regular and irregular polygons - triangles, squares, rectangles, parallelograms, other quadrilaterals, pentagons, hexagons, heptagons, octagons circles</li> <li>• similarities and differences between rectangles and parallelograms</li> </ul> </li> <li>• Characteristics of shapes</li> <li>• Describe, sort and compare 2D shapes in terms of               <ul style="list-style-type: none"> <li>• number of sides</li> <li>• lengths of sides</li> <li>• sizes of angles                   <ul style="list-style-type: none"> <li>• acute</li> <li>• right</li> <li>• obtuse</li> <li>• straight</li> <li>• reflex</li> <li>• revolution</li> </ul> </li> </ul> </li> <li>• Draw 2D shapes on grid paper</li> <li>• Draw circles, patterns in circles and patterns with circles using a pair of pair of compasses</li> <li>• Recognize and name the following angles in 2D shapes:               <ul style="list-style-type: none"> <li>• acute</li> <li>• right</li> <li>• obtuse</li> <li>• straight</li> <li>• reflex</li> <li>• revolution</li> </ul> </li> </ul>	<ul style="list-style-type: none"> <li>• Classifying 2D shapes</li> <li>• Revise properties and definitions of triangles in terms of their sides and angles, distinguishing between:               <ul style="list-style-type: none"> <li>• equilateral triangles</li> <li>• isosceles triangles</li> <li>• right-angled triangles</li> </ul> </li> <li>• Revise and write clear definitions of quadrilaterals in terms of their sides, angles and diagonals, distinguishing between:               <ul style="list-style-type: none"> <li>• parallelogram</li> <li>• rectangle</li> <li>• square</li> <li>• rhombus</li> <li>• trapezium</li> <li>• kite</li> </ul> </li> <li>• Similar and congruent triangles</li> <li>• Through investigation, establish the minimum conditions for congruent triangles</li> <li>• Through investigation, establish the minimum conditions for similar triangles</li> <li>• Solve geometric problems involving unknown sides and angles in triangles and quadrilaterals, using known properties of triangles and quadrilaterals, as well as properties of congruent and similar triangles</li> </ul>



## GLOSSARY OF TERMS

Term	Explanation / Diagram
<b>1-dimensional</b>	In geometry a line: <ul style="list-style-type: none"> <li>• Can be drawn between two points</li> <li>• Or can close in on itself like a circle</li> <li>• Can be straight or curved</li> <li>• Has no thickness, therefore does not take up space</li> <li>• Can extend in both directions without end</li> </ul>
<b>2-dimensional</b>	2-D objects take up an area on a flat surface, called a plane. It can be measure in two directions, for example the length and the width of a rectangle can be measured. The sides of the shape are lines – straight or curved.
<b>3-dimensional</b>	A 3D shape is an object that has height, width and depth, like any object in the real world.
<b>Polygon</b>	2-D shapes enclosed within at least 3 straight sides, such as triangles and parallelograms.
<b>Angles</b>	An angle is formed by two arms (lines) which join at a vertex. It is measured in degrees.
<b>Parallel</b>	In geometry, <b>parallel</b> lines are lines that do not meet. An example from everyday life would be a railway line.
<b>Revolution</b>	Is a $360^\circ$ angle [a circle].
<b>Circle</b>	A closed curve which is everywhere the same distance from a central point.
<b>Compass</b>	An instrument used with a pencil which is used to draw circles.
<b>Regular Shapes</b>	A regular shape means that all the angles are equal in size and all the sides are of equal length.
<b>Irregular Shapes</b>	A polygon that does not have all sides equal and the angles are also not always equal.
<b>Convex and Concave</b>	A convex polygon has no angles pointing inwards. A concave polygon has a side or sides that cave in.



## SUMMARY OF KEY CONCEPTS

### Angles

#### Classify Angles

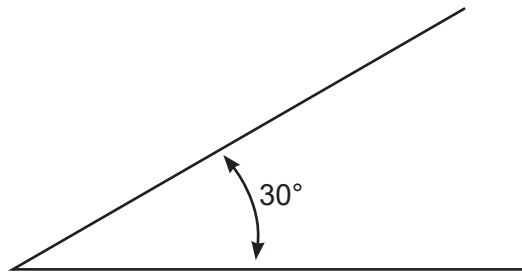

Acute angle: less than  $90^\circ$

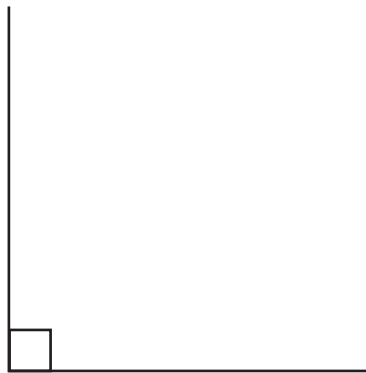

Right angle:  $90^\circ$

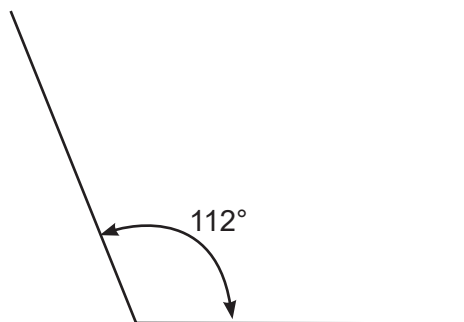

Obtuse angle: more than  $90^\circ$  but less than  $180^\circ$



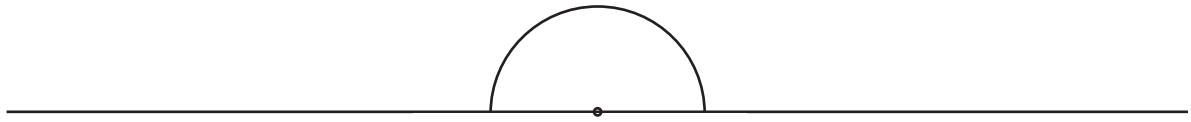

Straight angle/line:  $180^\circ$

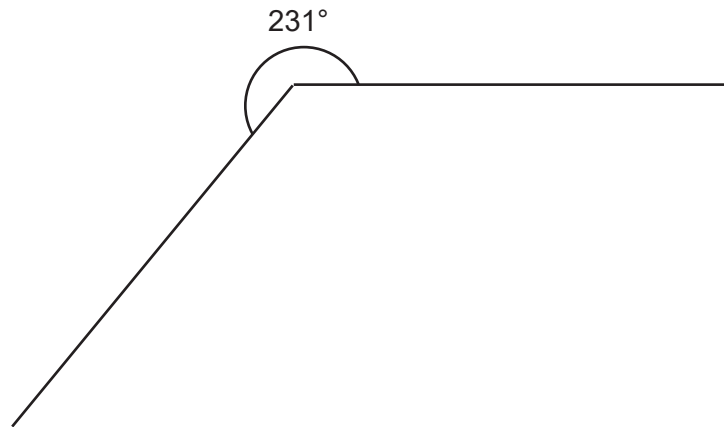

Reflex angle: more than  $180^\circ$  but less than  $360^\circ$

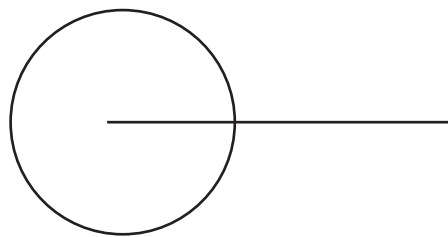

$360^\circ$ : known as a revolution

## Draw circles using a pair of compasses

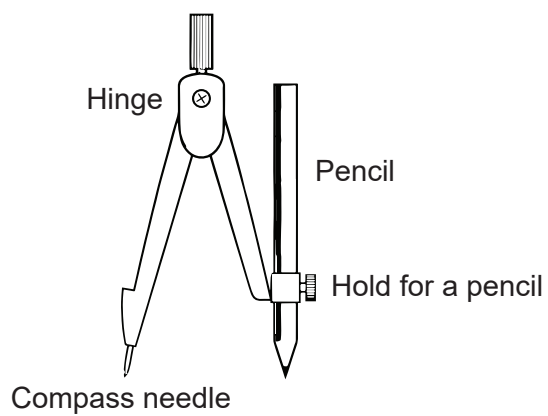

## Topic 4: Properties of 2D Shapes

To draw a circle with a compass:

1. Make sure that the hinge at the top of the compass is tight, so that it does not slip.
2. Tighten the grip for the pencil also, so it does not slip.
3. Check that the pencil is aligned with the compass's needle.
4. Press down the needle onto your paper, and turn the top of the compass to draw a circle.

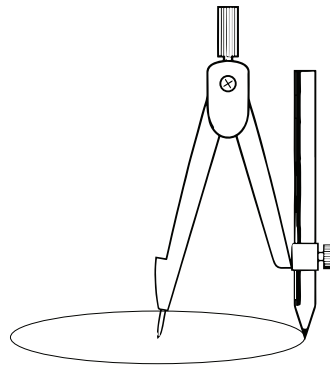

### Draw 2D shapes on grid paper

Octagon

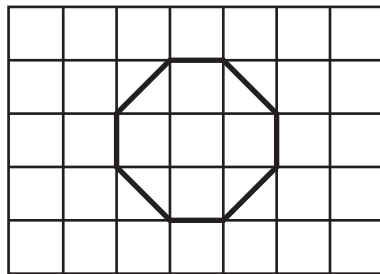

Rectangle

Use the grid to guide the drawing of the shape.

Shapes can be made as large or small as needed.

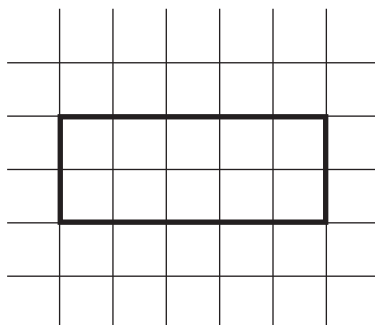

## Circle patterns using a pair of compasses

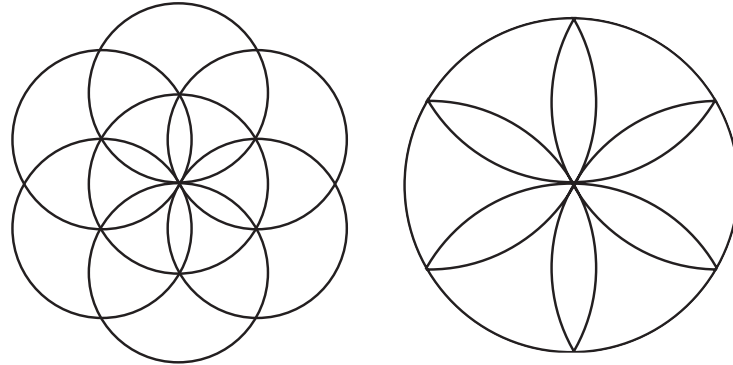

## Recognise and name the angles, length of sides and number of sides in 2D shapes:

Please refer to Topic 8 in the Grade 4 booklet, where a fairly complete list of 2D shapes and their properties appear.

### 1. Squares and other quadrilaterals

Properties of quadrilaterals:

Four sides (edges)

Four vertices (corners)

The interior angles add up to 360 degrees

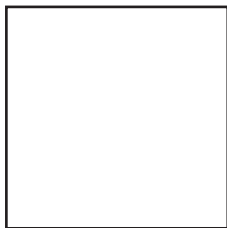

Square

$$4 \times 90^\circ = 360^\circ$$

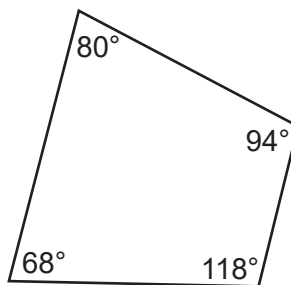

Quadrilateral

$$80^\circ + 94^\circ + 68^\circ + 118^\circ = 360^\circ$$

### a. Square

A square has:

- 4 angles of  $90^\circ$
- 4 sides of equal length
- 2 sets of parallel lines

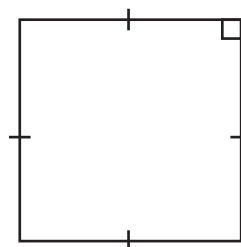

## Topic 4: Properties of 2D Shapes

### b. Rectangle

A rectangle is:

- a 4-sided shape
- angles are  $90^\circ$
- 2 sides are parallel and equal in length and the other two parallel sides of equal length

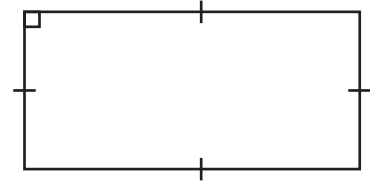

### c. Parallelogram

A parallelogram has:

- opposite sides parallel and equal in length.
- opposite angles are equal (angles 'a' are the same, and angles 'b' are the same).

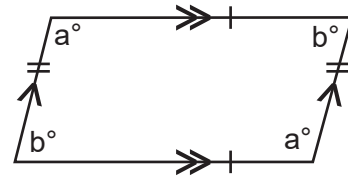

### d. Rhombus

A rhombus is a four-sided shape:

- all sides have equal length
- opposite sides are parallel
- opposite angles are equal.
- diagonals meet in the middle at a right angle.

In other words they bisect (cut in half) each other at right angles.

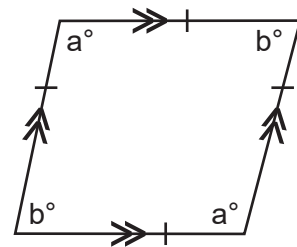

### e. Kite

A kite has:

- 2 pairs of adjacent sides are equal in length
- One pair of diagonally opposite angles is equal.
- One diagonal is bisected by the other.
- The diagonals cross at  $90^\circ$ .

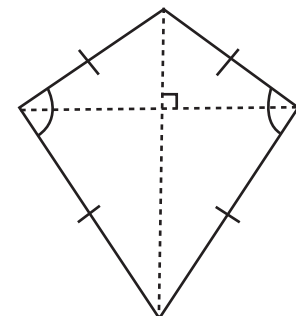

### f. Trapezium

A trapezium:

- is a quadrilateral with one pair of parallel sides
- the length of the sides may be all different

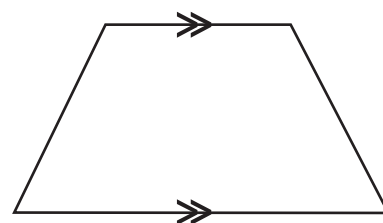

### 2. Similarities and differences between rectangles and parallelograms

a. The difference between a rectangle and a parallelogram is that:

- in a rectangle the angles are  $90^\circ$
- and in a parallelogram the opposite angles are of equal size but not  $90^\circ$

b. The similarities are:

- both have two sets of parallel lines
- the angles of both shapes add up to  $360^\circ$
- both have two pairs of lines of equal length

### 3. Pentagon

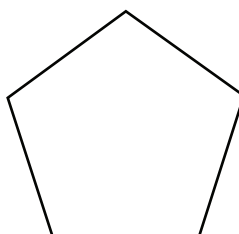

A pentagon is a 5-sided figure

### 4. Hexagon

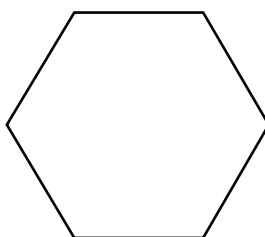

A hexagon has 6 sides

## Topic 4: Properties of 2D Shapes

### 5. Heptagon

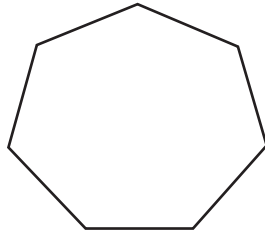

A heptagon has 7 sides

### 6. Octagon

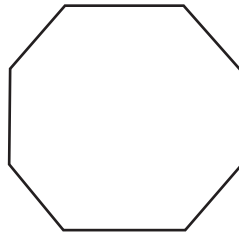

An octagon is an 8-sided figure.

Make each shape using paper or card.

# TOPIC 5: DATA HANDLING

## INTRODUCTION

- This unit runs for 10 hours.
- This unit is part of the content area Data Handling. This counts for 10% of the final exam.
- The unit covers the concept of Data Handling using a variety of graphs. Learners need to understand different ways in which graphs may be represented and they also need to be able to critically read and interpret the data.
- The purpose of this section is to develop skills and to prepare learners to survey, draw and design their own bar and pictographs. They develop their skills to read these graphs and pie graphs. New concepts and vocabulary are introduced and their critical thinking skills are developed

## SEQUENTIAL TEACHING TABLE

INTERMEDIATE PHASE / GRADE 5	GRADE 6	GRADE 7 SENIOR PHASE / FET PHASE
LOOKING BACK	CURRENT	LOOKING FORWARD
<ul style="list-style-type: none"> <li>• Collect data using tally marks and tables for recording</li> <li>• Order data from smallest group to largest group</li> <li>• Draw a variety of graphs to display and interpret data including: pictographs [many-to-one correspondence bar graphs</li> <li>• Critically read and interpret data represented in words pictographs bar graphs pie charts</li> <li>• Analyse data by answering questions related to: data categories data sources and contexts</li> <li>• Summarise data verbally and in short written paragraphs that include: drawing conclusions about the data making predictions based on the data</li> <li>• Examine ungrouped numerical data to determine: the most frequently occurring score in the data set [mode]</li> </ul>	<ul style="list-style-type: none"> <li>• Collect data using tally marks and tables for recording-- using simple questionnaires [yes/no type response]</li> <li>• Order data from smallest group to largest group</li> <li>• Draw a variety of graphs to display and interpret data including: pictographs [many-to-one correspondence] bar graphs and double bar graphs</li> <li>• Critically read and interpret data represented in               <ul style="list-style-type: none"> <li>• words</li> <li>• pictographs</li> <li>• bar graphs</li> <li>• double bar graphs</li> <li>• pie charts</li> </ul> </li> <li>• Analyse data by answering questions related to: data categories, including data intervals data sources and contexts</li> <li>• central tendencies – [mode and median]</li> </ul>	<ul style="list-style-type: none"> <li>• Collect data</li> <li>• Pose questions relating to social, economic, and environmental issues</li> <li>• Select and justify appropriate sources for the collection of data</li> <li>• Distinguish between samples and populations, and suggest appropriate samples for investigation</li> <li>• Select and justify appropriate methods for collecting data</li> <li>• Organize numerical data in different ways in order to summarize by determining:               <ul style="list-style-type: none"> <li>-- measures of central tendency</li> <li>-- measures of dispersion, including extremes and Outliers</li> </ul> </li> <li>• Organize data according to more than one criteria</li> <li>• Critically read and interpret data represented in a variety of ways</li> <li>• Critically compare two sets of data related to the same issue</li> <li>• Critically analyse data by answering questions related to: data collection methods, summary of data and sources of error and bias in the data</li> </ul>



INTERMEDIATE PHASE / GRADE 5	GRADE 6	GRADE 7 SENIOR PHASE / FET PHASE
LOOKING BACK	CURRENT	LOOKING FORWARD
	<ul style="list-style-type: none"> <li>• Summarise data verbally and in short written paragraphs that include: drawing conclusions about the data making predictions based on the data</li> <li>• Examine ungrouped numerical data to determine: the most frequently occurring score in the data set [mode] the middlemost score in the data set [median]</li> </ul>	<ul style="list-style-type: none"> <li>• Summarize data in short paragraphs that include: drawing conclusions about the data making predictions based on the data making comparisons between two sets of data identifying sources of error and bias in the data</li> <li>• Choosing appropriate summary statistics for the data [mean, median, mode, range]</li> <li>• The role of extremes and outliers in the data</li> </ul>

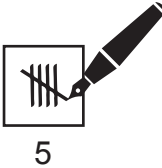

## GLOSSARY OF TERMS

Term	Explanation / Diagram
<b>x axes and y axes</b>	On a coordinate plane, also called a Cartesian plane, there is a coordinate system where a horizontal x-axis is marked from a zero point to the left in negative numbers and to the right in positive numbers. This axis is crossed at the zero point at right angles by a y-axis, which is marked from the zero point upwards in positive whole numbers and downwards in negative numbers.
<b>Mode</b>	This is the number that appears the most in the data set.
<b>Mean</b>	This is the average – this is the sum of the data divided by the number of data.
<b>Median</b>	This is the number in the middle, if data is arranged from lowest to highest / highest to lowest.
<b>Range</b>	This is the difference between the largest and the smallest numbers of the data.
<b>Tally</b>	<p>The word tally is used both as a verb and a noun. To tally simply means to keep a count and the tally is the written counting. Let us say for example one counts the cars passing at a robot, you draw a line for each car that passes and to make the calculation of the total of your lines easier, you cross out every four vertical lines by a horizontal line, which is your 5th count.</p> <div style="text-align: center;">  </div>
<b>Bar graph</b>	This type of graph uses bars to show the data. That which is measured, appears on the x-axis and the number or measurement is indicated on the y-axis.
<b>Pie graph</b>	A pie chart is a circular statistical graphic, which is divided into slices to illustrate numerical proportion. In a pie chart, the size of each slice is proportional to the quantity it represents.
<b>Pictographs</b>	A pictograph uses pictures or symbols to represent an amount of data. The key for a pictograph tells the number that each picture or symbol represents.
<b>Double bar</b>	We can use a double bar graph to compare two data groups. A double bar graph has two axes. The x-axis of a double bar graph shows the categories being compared, and the y-axis represents the scale. A scale is a set of numbers that represents the data organized into equal intervals.
<b>Data</b>	Data is information that is presented in a condensed form for use in reports, planning, analysis and more.



## SUMMARY OF KEY CONCEPTS

### Summary Statistical Terms

#### 1. Mode

This is the number that appears the most.

3, 3, 3, 6, 7, 7, 13

3 is the mode

#### 2. Median

This is the number in the middle, if data is arranged from lowest to highest.

e.g. 3, 3, 3, 6, 7, 7, 13

6 is the middle number

### How to label and layout a graph

1. Decide on a title for your graph (What kind of pet do you own).
2. Draw the vertical and horizontal axes.
3. Label the horizontal axes (Type of Pet).
4. Write the names of pets where the bars will be (Dog, Cat etc).
5. Label the vertical axes (Number of People).
6. Decide on the scale.
7. Draw the bars to the correct height and with the same width, evenly spaced.

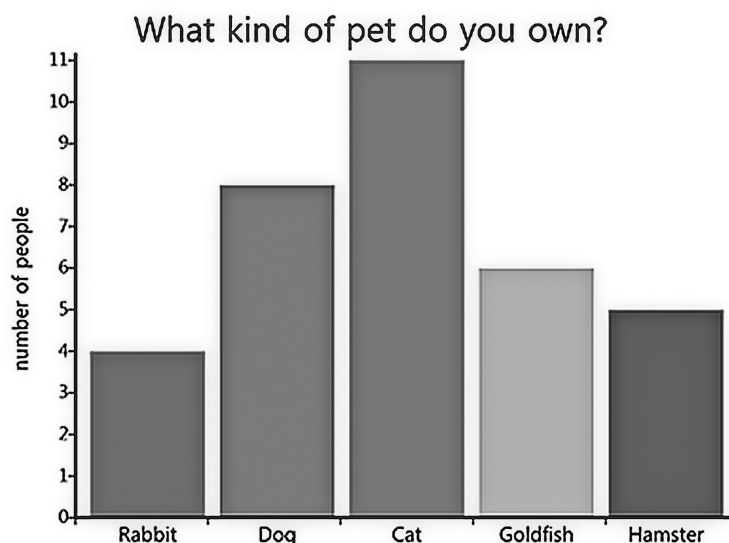

# Topic 5: Data Handling

## Collecting and ordering data

### 1. Data Collection

Data can be collected in different ways.

- The simplest way is observation.
- Example: you want to find how many cars pass by a certain point on a road in a 10-minute interval.
- So: stand at that point on the road, and count the cars that pass by in that interval.
  - a. Data can be collected by doing surveys

To do this:

Survey people (through questionnaires, opinion polls, etc.) or things (like pollution levels in a river, or favourite colours).

Here are four steps to a successful survey:

- draw up the questions
  - ask the questions
  - tally the results
  - present the results
- b. Data can be recorded by using tally marks.

This is how you record the items:

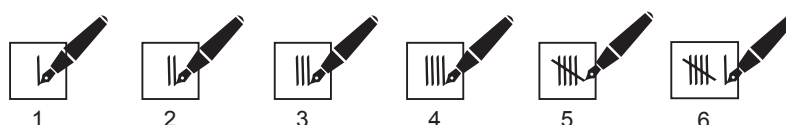

- c. When doing a simple survey, tally each person's answers:

<b>Yellow</b>		<b>4</b>
<b>Red</b>		<b>5</b>
<b>Blue</b>		<b>6</b>
<b>Green</b>		<b>1</b>
<b>Pink</b>		<b>4</b>

Order the data from largest to smallest.

So blue has the most with 6, then red with 5, followed by pink and yellow with 4 each and lastly green with 1.

## Types of graphs

### 1. Pictograph: many-to-one

This type of graph uses images to represent what is being compared.

This is a many-to-one as one picture of an apple represents 10 apples.

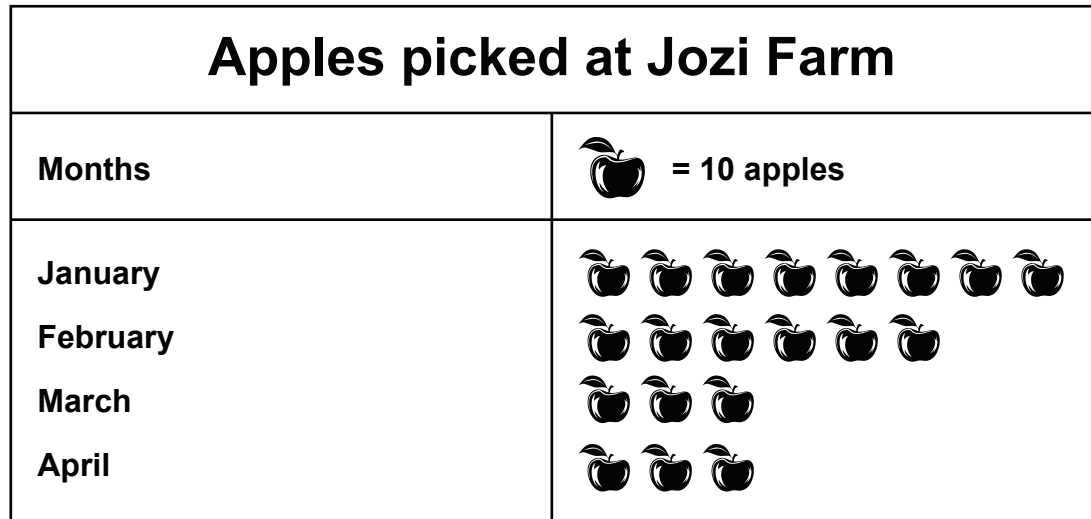

### 2. Bar graph

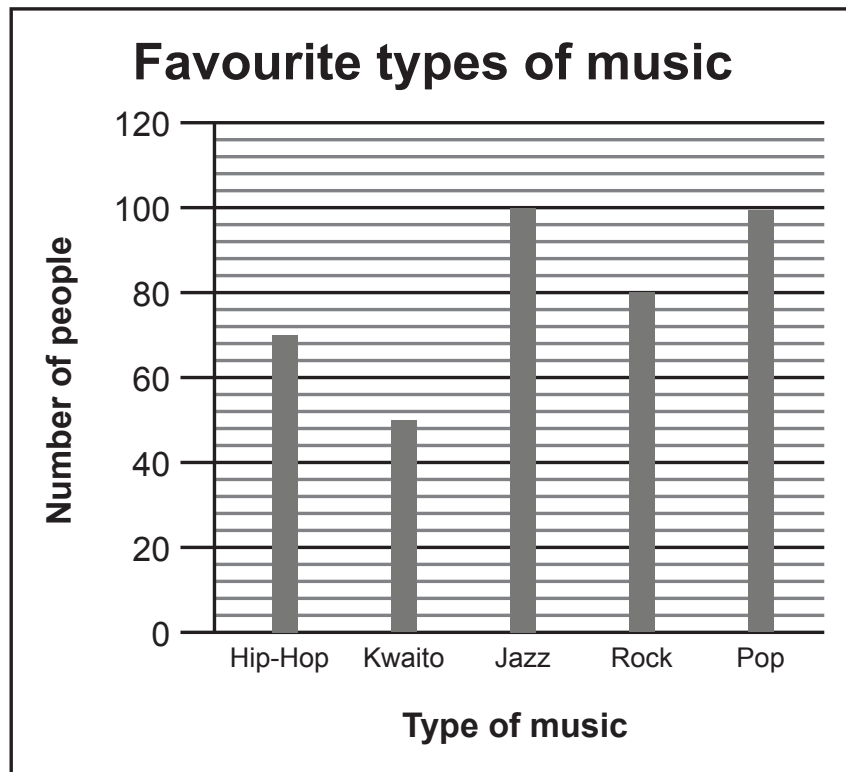

## Topic 5: Data Handling

To draw a bar graph:

- Work out a scale; so that it is equally spaced and can fit on a page. The scale can go up in ones, fives, tens, or hundreds.
- Have a title.
- Label the x and y axes.
- Draw the columns or bars and leave an equal space between each bar.
- Label each column.
- Colour the columns or bars - use different colours or patterns.

### 3. Pie graphs

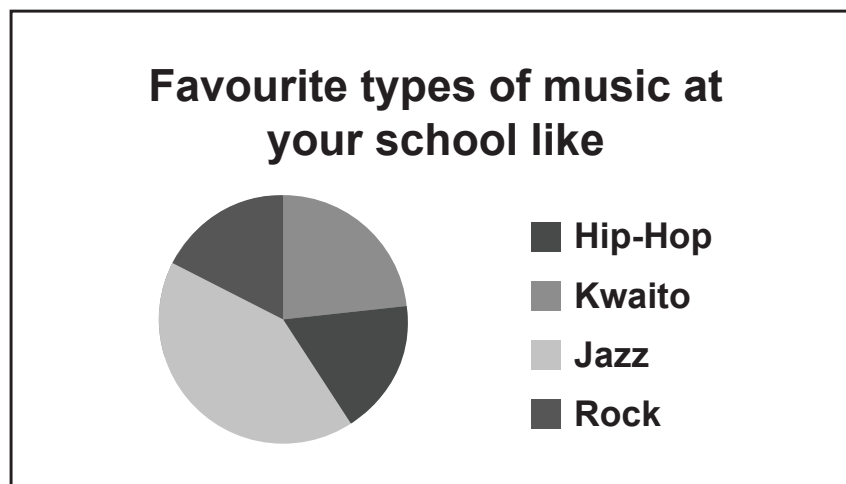

Each slice is a fraction of the whole.

Each slice represents what percentage or fraction of people who like each type of music.

In Grade 6 Pie charts are only for analysis and not drawing.

## Analyse and Interpret Data

### 1. Useful questions to analyse data:

Ask learners questions such as:

- What pattern do you see?
- What does this graph tell you?
- Who could use this data?
- Why is this data shown in a ...graph?
- Which [two] values are compared?
- What is the relationship between the data sets?
- Why do you think there is a relationship?
- Was this a valid sample of the population?
- What conclusions can be drawn about the data? Why?

### 2. Tips for learners to analyse data.

- Is my data source valid?
- What are the different categories of data?
- What problem am I trying to solve?
- Are there places where the data are concentrated or clumped?
- Do I have enough background information to analyse this data?
- What is the median and mode?

# TOPIC 6: NUMERIC PATTERNS

## INTRODUCTION

- This unit runs for 4 hours.
- This unit is part of the content area Patterns, Functions and Algebra. This counts for 10% of the final exam.
- The unit covers the concept of numeric patterns. Learners need to use flow-charts and tables to calculate. They need to understand and develop the use of in-put, rules and out-put values.
- The purpose of this section is to develop skills needed for algebra. New concepts and vocabulary are introduced.



## SEQUENTIAL TEACHING TABLE

INTERMEDIATE PHASE / GRADE 5	GRADE 6	GRADE 7 SENIOR PHASE / FET PHASE
LOOKING BACK	CURRENT	LOOKING FORWARD
<ul style="list-style-type: none"> <li>Investigate and extend numeric patterns looking for relationships or rules of patterns: -- sequences not limited to a constant difference or ratio -- of learner's own creation</li> <li>Describe observed relationships or rules in learner's own words</li> <li>Investigate and extend geometric patterns looking for relationships or rules of patterns -- represented in physical or diagram form -- sequences not limited to a constant difference or ratio -- of learner's own creation</li> <li>Describe observed relationships or rules in learner's own words</li> <li>Determine input values, output values and rules for the patterns and relationships using flow diagrams</li> <li>Determine equivalence of different descriptions of the same relationship or rule presented               <ul style="list-style-type: none"> <li>verbally</li> <li>in a flow diagram</li> <li>by a number sentence</li> </ul> </li> </ul>	<ul style="list-style-type: none"> <li>Investigate and extend numeric patterns looking for relationships or rules of patterns: -- sequences not limited to a constant difference or ratio -- of learner's own creation -- represented in tables</li> <li>Describe the general rules for the observed relationships</li> <li>Investigate and extend geometric patterns looking for relationships or rules of patterns -- represented in physical or diagram form -- sequences not limited to a constant difference or ratio -- of learner's own creation -- represented in tables</li> <li>Describe the general rules for the observed relationships</li> <li>Determine input values, output values and rules for the patterns and relationships using flow diagrams tables</li> <li>Determine equivalence of different descriptions of the same relationship or rule presented               <ul style="list-style-type: none"> <li>verbally</li> <li>in a flow diagram</li> <li>in a table</li> <li>by a number sentence</li> </ul> </li> </ul>	<ul style="list-style-type: none"> <li>Investigate and extend numeric and geometric patterns looking for relationships between numbers, including patterns:               <ul style="list-style-type: none"> <li>represented in physical or diagram form -- not limited to sequences involving a constant difference or ratio -- of learner's own creation -- represented in tables -- represented algebraically</li> </ul> </li> <li>Describe and justify the general rules for observed relationships between numbers in own words or in algebraic language</li> </ul>



## GLOSSARY OF TERMS

Term	Explanation / Diagram
<b>Pattern</b>	A sequence of numbers where each consecutive term follows a rule so that the pattern repeats in a predictable manner. Example: 4, 7, 10, 13...
<b>Input</b>	A given number to which a rule [specific operations] will be applied.
<b>Output</b>	The result when a rule [specific operations] were applied to an input number. Example: In the above pattern, the input values 1, 2, 3, 4... may be given, and the rule applied: multiply by 3 and add 1, when then gives the output numbers 4, 7, 10, 13...
<b>Flow diagram</b>	A diagram which flows horizontally from the input number[s] through the rule [operations] to the output number[s].
<b>Relationships</b>	Consecutive terms stand in a relationship to each other. In our example, the relationship is a constant difference of 3. Output numbers stand in a relationship to input numbers. This relationship is determined by the rule of the pattern.



## SUMMARY OF KEY CONCEPTS

Input values, rules, and output values for patterns and relationships using flow diagrams.

1. A flow diagram with one operation:

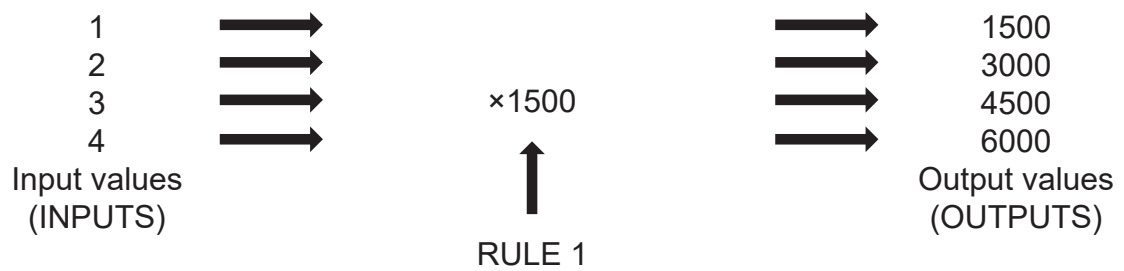

2. A flow diagram with multiple operations:

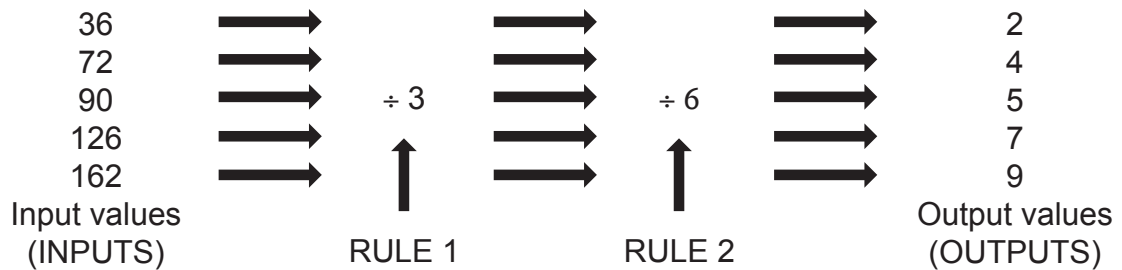

3. Number patterns as a table

	1	2	3	4	5	6	7	9
$\times 2$	2	4	6	8	10	12	14	18
$+ 3$	5	7	9	11	13	15	17	19

# Notes



# Notes