

**MATHEMATICS**

**Grade 1**

**English/  
Tshivenda**

**Learner**

**Activity**

**Book**

**2020 TERM 1**



# Introduction

This resource pack has fifty numbered daily activities for classwork and homework. The activities correspond to the activities in the lesson plans. Answers to the activities can be written in this book.

These resources are bilingual. We hope that presenting the activities in two languages will help learners to learn the maths words in both their home language and in English. This will equip them for lifelong learning of maths.

If learners work systematically through these maths activities, they will cover the whole curriculum. Hopefully these activities will be a fun way to help them acquire this maths knowledge.

# Marangaphanna

Phekhe iyi ya zwiko i na nyito dza fuṭhanu dza ḡuvha na ḡuvha dzo nomboriwaho, dzi dza mushumo wa kiḡasini na tshuṅwahaya. Nyito idzi dzi yelana na nyito dzi re kha pulane dza ngudo. Mbudziso dza nyito dzi nga fhindulelwa buguni iyi.

Zwiko izwi zwi kha nyambo mbili. Ri na fulufhelo ḡa uri u shuma nga nyambo mbili zwi ḡo thusa vhagudi uri vha gude maipfi a mbalo nga luambo lwavho lwa hayani na nga English (Luisimane). Hezwi zwi ḡo vha pfundisela (lugisela) u dzhena kha u guda mbalo ha vhutshilo hoṭhe – ha tsiavhafu.

Arali vhagudi vha nga shuma mishumo iyi i tshi ṭandulukana (nga sisiṭeme), vha ḡo kona u khunyeledza kharikhuḡamu yoṭhe. Ri na fulufhelo ḡa uri, musi vhagudi vha tshi khou ita nyito idzi, vha ḡo vha vha tshi khou guda mbalo hu na u ḡiphina.





# Contents

## Zwi re ngomu

Term 1 Lesson 1: Position of objects	5
Themo ya 1 Ngudo ya 1: Vhuimo ha zwithu	
Term 1 Lesson 2 Position of objects	6
Themo ya 1 Ngudo ya 2 Vhuimo ha zwithu	
Term 1 Lesson 3 Position of objects	9
Themo ya 1 Ngudo ya 3 Vhuimo ha zwithu	
Term 1 Lesson 4 Matching things	10
Themo ya 1 Ngudo ya 4 U livhanya zwithu	
Term 1 Lesson 5 Consolidation	11
Themo ya 1 Ngudo ya 5 U ṭanganya magudiswa	
Term 1 Lesson 6 Numbers	13
Themo ya 1 Ngudo ya 6 Nomboro	
Term 1 Lesson 7 Assessment	15
Themo ya 1 Ngudo ya 7 U linga	
Term 1 Lesson 8 Numbers 1 to 5	15
Themo ya 1 Ngudo ya 8 Nomboro 1 u swika kha 5	
Term 1 Lesson 9 Numbers 1 and 2	16
Themo ya 1 Ngudo ya 9 Nomboro 1 na 2	
Term 1 Lesson 10 Consolidation	17
Themo ya 1 Ngudo ya 10 U ṭanganya magudiswa	
Term 1 Lesson 11 Numbers 3 and 4	19
Themo ya 1 Ngudo ya 11 Nomboro 3 na 4	
Term 1 Lesson 12 Number 5	21
Themo ya 1 Ngudo ya 12 Nomboro ya 5	
Term 1 Lesson 13 Compare and order numbers 1 to 5	22
Themo ya 1 Ngudo ya 13 U vhambedza na u dubekanya nomboro 1 u swika kha 5	
Term 1 Lesson 14 Numbers 6 to 10	25
Themo ya 1 Ngudo ya 14 Nomboro 6 uswika kha 10	
Term 1 Lesson 15 Consolidation	26
Themo ya 1 Ngudo ya 15 U ṭanganya magudiswa	
Term 1 Lesson 16 Assessment	27
Themo ya 1 Ngudo ya 16 U linga	
Term 1 Lesson 17 Numbers 6 and 7	27
Themo ya 1 Ngudo ya 17 Nomboro 6 na 7	
Term 1 Lesson 18 Numbers 8 and 9	29
Themo ya 1 Ngudo ya 18 Nomboro 8 na 9	
Term 1 Lesson 19 Number 10	30
Themo ya 1 Ngudo ya 19 Nomboro ya 10	
Term 1 Lesson 20 Consolidation	31
Themo ya 1 Ngudo ya 20 U ṭanganya magudiswa	
Term 1 Lesson 21 Assessment	33
Themo ya 1 Ngudo ya 21 U linga	
Term 1 Lesson 22 Number bonds of 6 and 7	34
Themo ya 1 Ngudo ya 22 Mbumbanomboro dza 6 na 7	
Term 1 Lesson 23 Number bonds of 8 and 9	35
Themo ya 1 Ngudo ya 23 Mbumbanomboro dza 8 na 9	
Term 1 Lesson 24 Number bonds of 10	37
Themo ya 1 Ngudo ya 24 Mbumbanomboro dza 10	
Term 1 Lesson 25 Consolidation	38
Themo ya 1 Ngudo ya 25 U ṭanganya magudiswa	
Term 1 Lesson 26 Number bonds 2 to 10	40
Themo ya 1 Ngudo ya 26 Mbumbanomboro 2 u swika kha 10	

Term I Lesson 27 Assessment	41
Themo ya I Ngudo ya 27 U linga	
Term I Lesson 28 Compare and order numbers 1 to 10	41
Themo ya I Ngudo ya 28 U vhambedza na u dubekanya nomboro 1 u swika kha 10	
Term I Lesson 29 Concept of zero	42
Themo ya I Ngudo ya 29 Muhumbulo wa zero/pumu	
Term I Lesson 30 Consolidation	44
Themo ya I Ngudo ya 30 U țanganya magudiswa	
Term I Lesson 31 Counting forwards and backwards	45
Themo ya I Ngudo ya 31 U vhalela phanda na murahu	
Term I Lesson 32 Number patterns	46
Themo ya I Ngudo ya 32 Phetheni dza nomboro	
Term I Lesson 33 Review of numbers 0 to 10	48
Themo ya I Ngudo ya 33 U sedzulusa nomboro 0 u swika kha 10	
Term I Lesson 34 Assessment	49
Themo ya I Ngudo ya 34 U linga	
Term I Lesson 35 Consolidation	49
Themo ya I Ngudo ya 35 U țanganya magudiswa	
Term I Lesson 36 Ordinal numbers	51
Themo ya I Ngudo ya 36 Nomboro thevhekani	
Term I Lesson 37 Ordinal and cardinal numbers	52
Themo ya I Ngudo ya 37 Nomboro thevhekani na nomboro ya khadinajla	
Term I Lesson 38 Assessment	54
Themo ya I Ngudo ya 38 U linga	
Term I Lesson 39 3-D objects - Constructing figures	54
Themo ya I Ngudo ya 39 Zwithu zwa 3-D - U fhatja zwivhumbiwa	
Term I Lesson 40 Consolidation	54
Themo ya I Ngudo ya 40 U țanganya magudiswa	
Term I Lesson 41 Properties of solids	55
Themo ya I Ngudo ya 41 Mbonalo ya zwiomate	
Term I Lesson 42 Balls and boxes	56
Themo ya I Ngudo ya 42 Bola na mabogisi	
Term I Lesson 43 2-D shapes	58
Themo ya I Ngudo ya 43 Zwivhumbeo zwa 2-D	
Term I Lesson 44 Assessment	59
Themo ya I Ngudo ya 44 U linga	
Term I Lesson 45 Consolidation	59
Themo ya I Ngudo ya 45 U țanganya magudiswa	
Term I Lesson 46 Faces of 3-D objects	61
Themo ya I Ngudo ya 46 Vhurumbu ha zwithu zwa 3-D	
Term I Lesson 47 Geometric patterns	61
Themo ya I Ngudo ya 47 Phetheni dza dzhometiri	
Term I Lesson 48 More geometric patterns	62
Themo ya I Ngudo ya 48 Phetheni dza dzhometiri dziinwe hafhu	
Term I Lesson 49 Assessment	63
Themo ya I Ngudo ya 49 U linga	
Term I Lesson 50 Consolidation	63
Themo ya I Ngudo ya 50 U țanganya magudiswa	

# Term | Lesson |

## Themo ya | Ngudo ya |

Position of objects

Vhuimo ha zwithu

START MATHOMONI

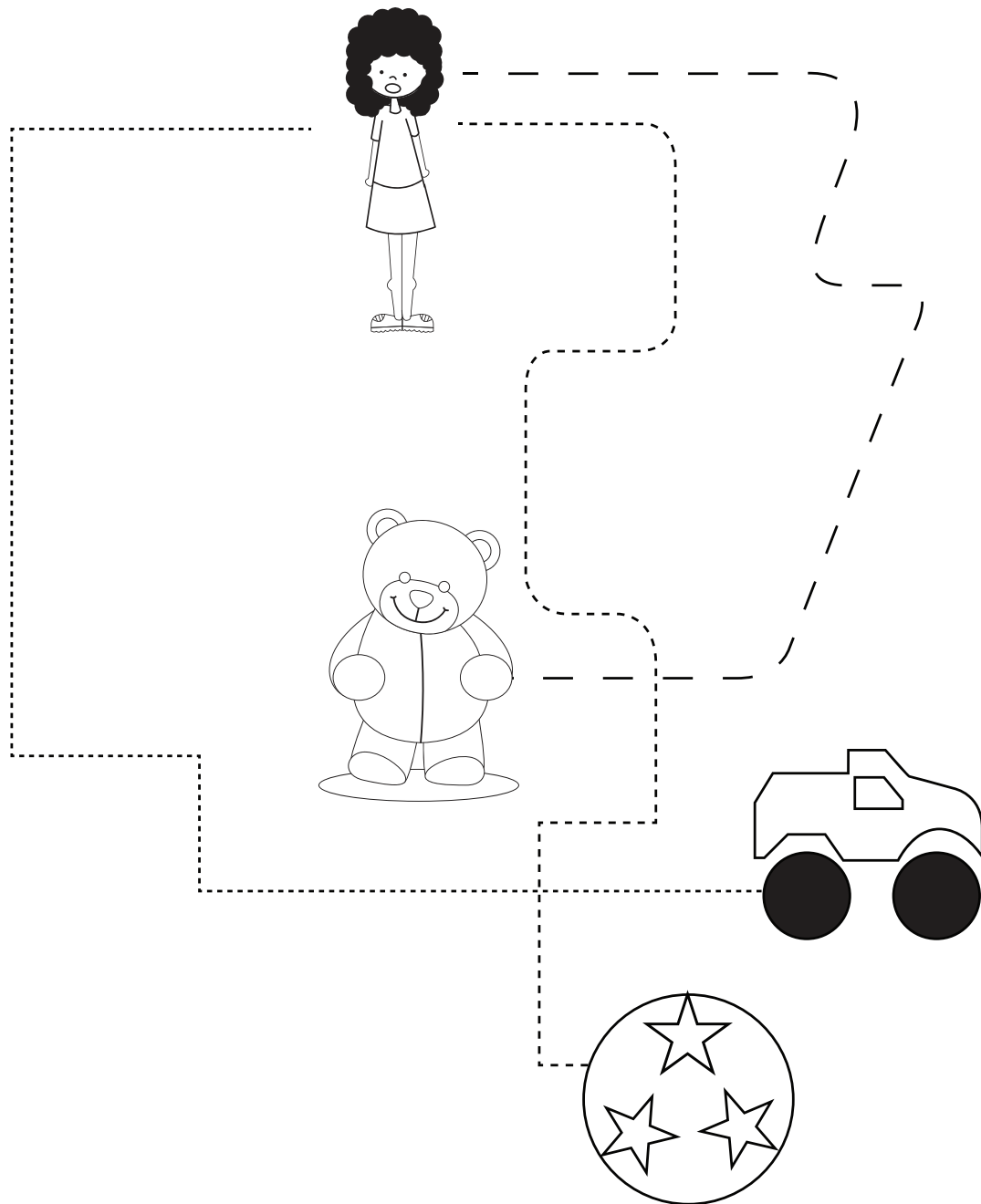

FINISH MAGUMONI

CLASSWORK MUSHUMO WA KIṬASINI

Look at the picture and tick the correct box.

Lavhelesani tshifanyiso ni ite thiki tshibogisini tsho teaho.

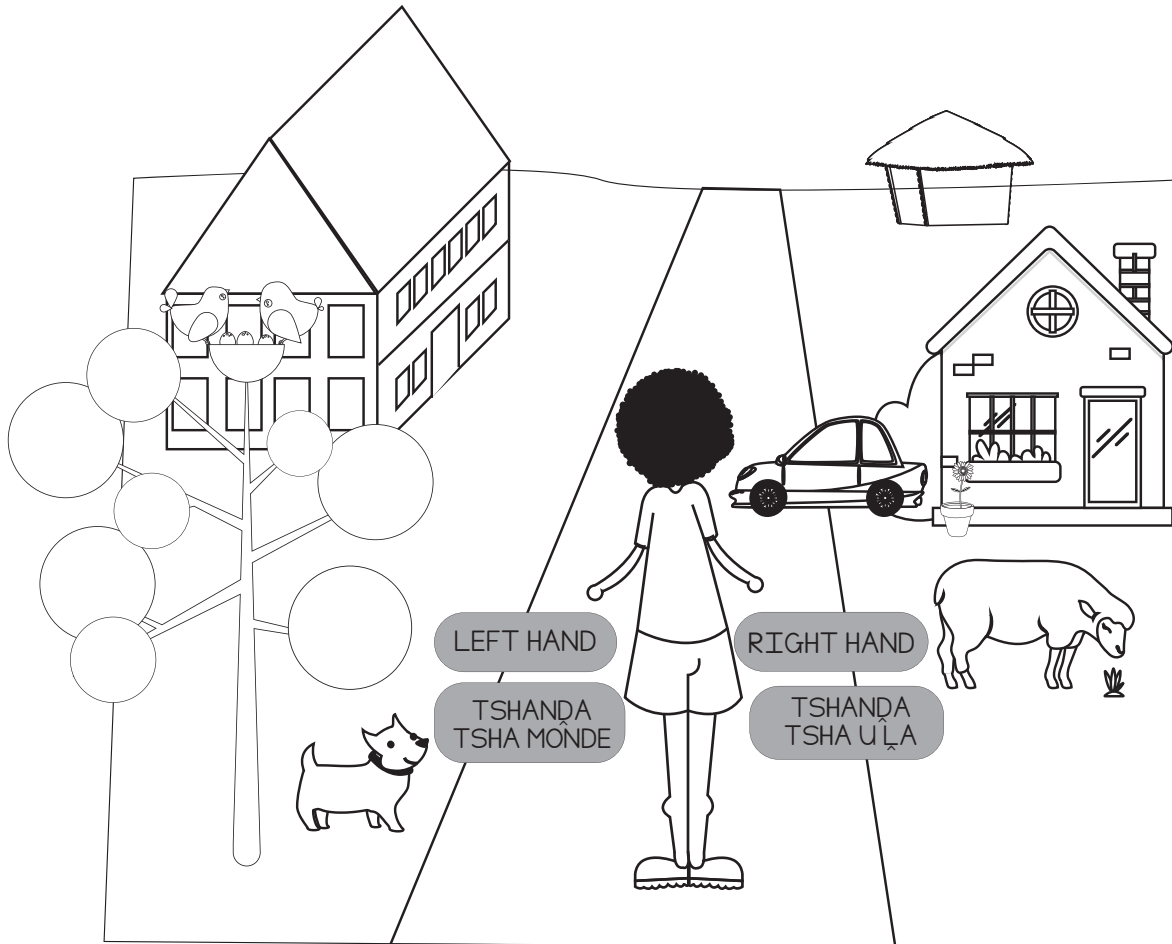

a The tree is on his \_\_\_\_\_.

Muri u kha \_\_\_\_\_ tshawe.

b The car is on his \_\_\_\_\_.

Moḡoro u kha \_\_\_\_\_ tshawe.

c The house is on his \_\_\_\_\_.

Nnḡu i kha \_\_\_\_\_ tshawe.

d The bird is on his \_\_\_\_\_.

Tshinoni tshi kha \_\_\_\_\_ tshawe.

e The nest is on his \_\_\_\_\_.

Tshitaha tshi kha \_\_\_\_\_ tshawe.

f The dog is on his \_\_\_\_\_.

Mmbwa i kha \_\_\_\_\_ tshawe.

g The sheep is on his \_\_\_\_\_.

Nngu i kha \_\_\_\_\_ tshawe.

h The hut is on his \_\_\_\_\_.

Nngu i kha \_\_\_\_\_ tshawe.

i The school is on his \_\_\_\_\_.

Tshikolo tshi kha \_\_\_\_\_ tshawe.

j The flower is on his \_\_\_\_\_.

Dzuvha li kha \_\_\_\_\_ tshawe.

EXTENSION NYINGANYITO

Start at the ● and trace the lines.

Thomani kha ● ni tevhedzele mitaladzi.

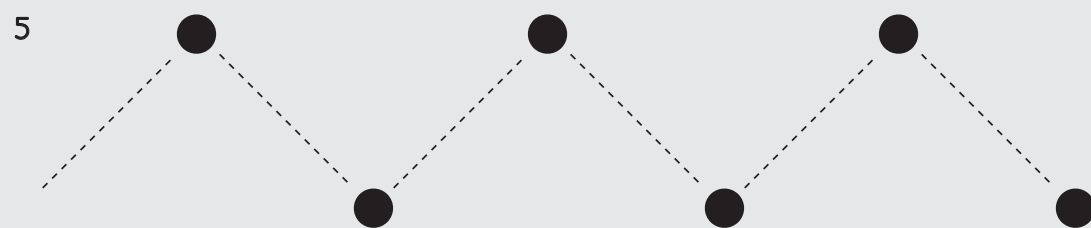
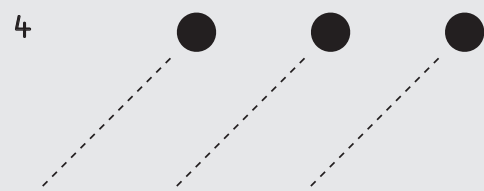
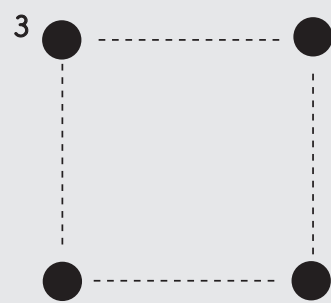
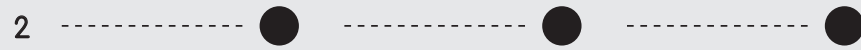
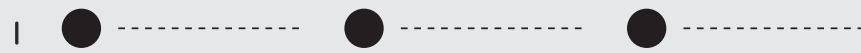

# Term 1 Lesson 2

## Themo ya I Ngudo ya 2

Position of objects

Vhuimo ha zwithu

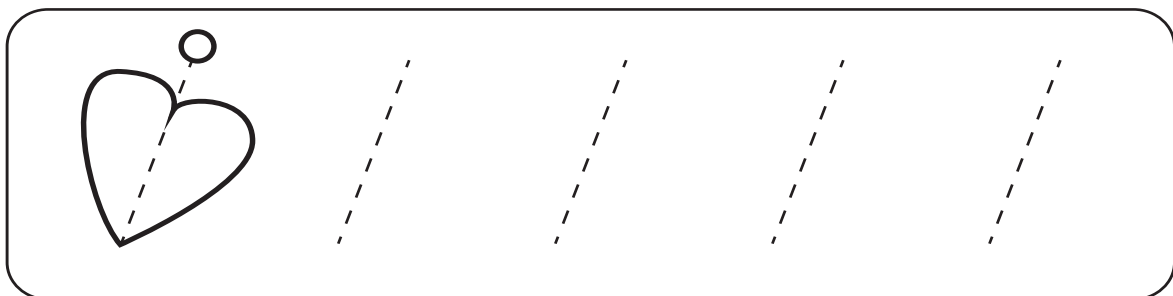
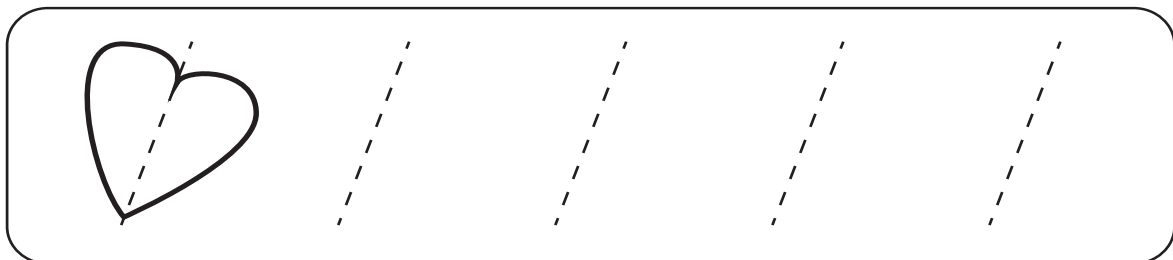
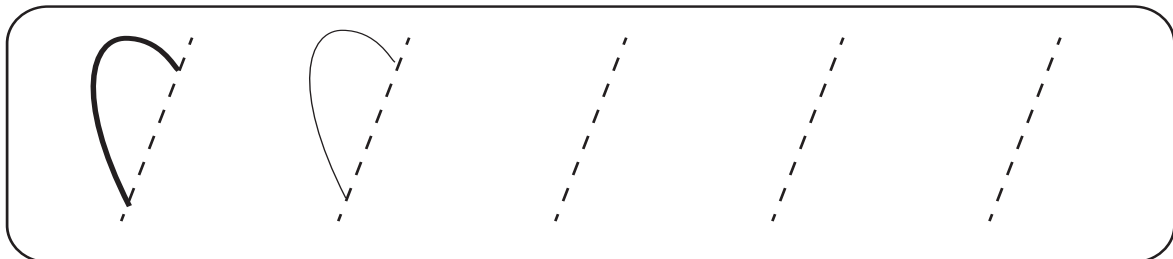
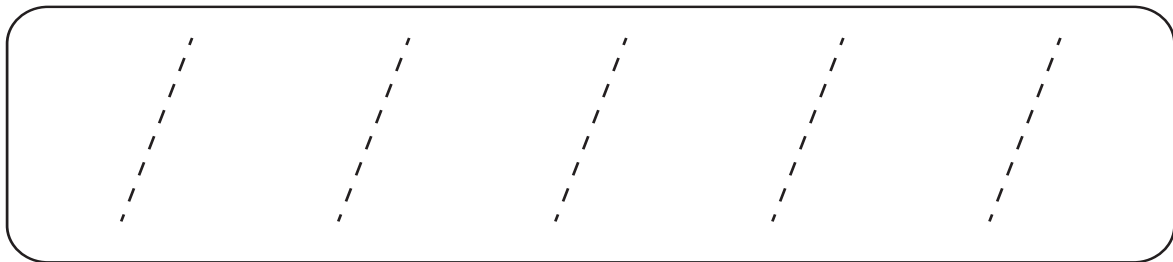

CLASSWORK MUSHUMO WA KILASINI

1 Circle the word that matches the direction of the arrow.

Tangedzelani ipfi li no yelana na he musevhe wa sumba hone.

↑	up n̄tha	left kha tsha monde	down fhasi	right kha tsha u la
↓	up n̄tha	left kha tsha monde	down fhasi	right kha tsha u la
→	up n̄tha	left kha tsha monde	down fhasi	right kha tsha u la
←	up n̄tha	left kha tsha monde	down fhasi	right kha tsha u la

2 Circle the arrow that matches the first arrow in the row.

Tangedzelani musevhe u no yelana na musevhe wa u thoma kha muduba (rou).

↑	→	←	↓	↑
↓	↑	↓	→	←
→	←	↓	→	↑
←	↑	←	↓	→



## EXTENSION NYINGANYITO

Complete the sentences below using these words.

Fhedzisani mafhungo ni tshi shumisa maipfi aya.

*above inside below in between*

*n̄tha ha ngomu ha fhasi ha vhukati ha*

1



The flower is \_\_\_\_\_ the box.

Dzuvha ḽi \_\_\_\_\_ tshibogisi.

2



The bicycle is \_\_\_\_\_ the box and the flower.

Baisigiri i \_\_\_\_\_ tshipogisi na dzuvha.

3



The bicycle is \_\_\_\_\_ the flower.

Baisigiri i \_\_\_\_\_ dzuvha.

4



The bicycle is \_\_\_\_\_ the flower.

Baisigiri i \_\_\_\_\_ dzuvha.

# Term 1 Lesson 3

## Themo ya 1 Ngudo ya 3

Position of objects

Vhuimo ha zwithu

### CLASSWORK MUSHUMO WA KILASINI

- 1 Circle the animal that is in the same position as the shaded block.

Tangedzelani tshipuka tshi re kha vhuimo vhuthihi na tshibu\oko tshi re na muvhala.

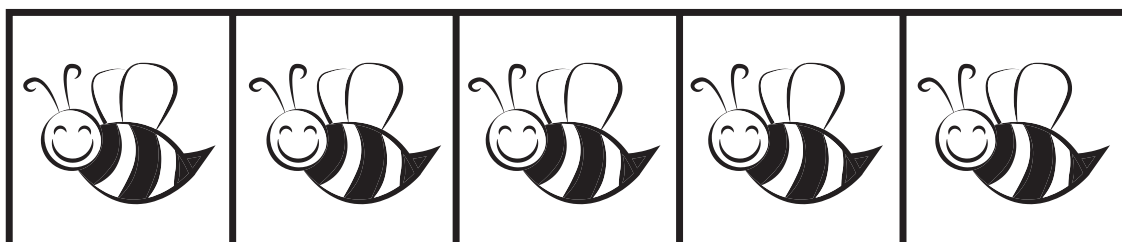
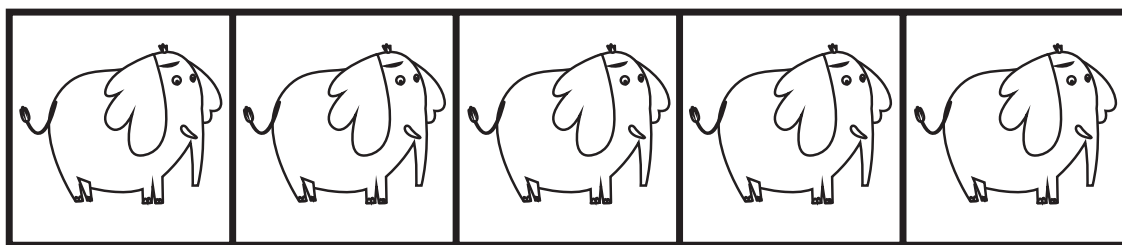
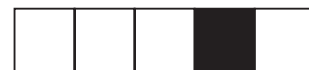
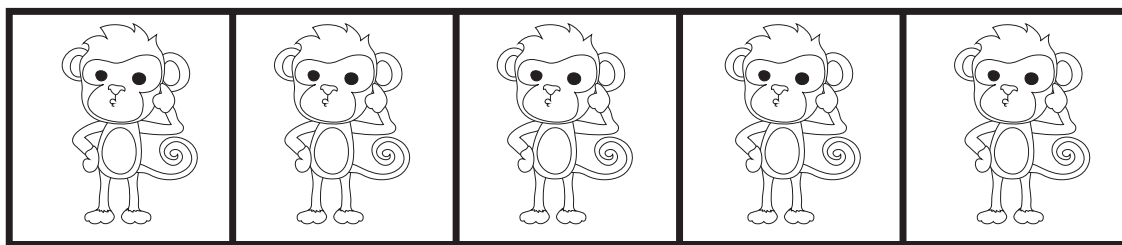

2 Colour the rest of the shapes.

Khalarani izwo zwiwwe zwivhumbeo.

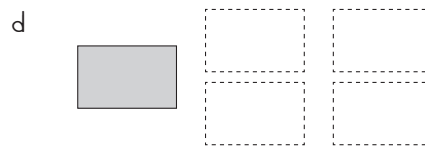
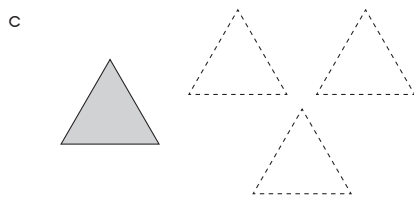
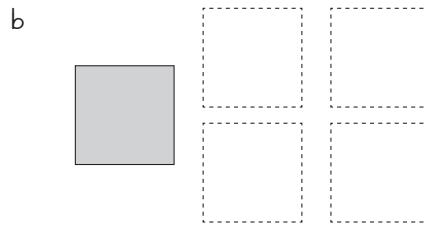
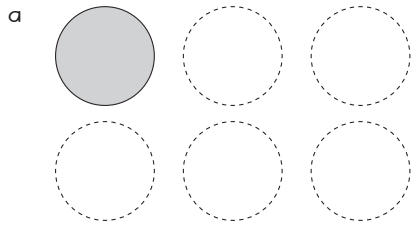

## EXTENSION NYINGANYITO

1 Draw a picture of a cat on top of a table in the box below.

Tshibogisini tshi re afho fhasi, olani tshifanyiso tsha tshimange tshi n̄tha ha tafula.

2 Complete the sentences below using these words.

Fhedzisani mafhungo a re afho fhasi ni tshi shumisa maipfi aya.

*in between*

*next to*

*after*

*before*

*vhukati ha*

*tsini na*

*tevhela*

*rangela*

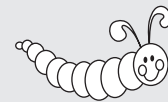

a The butterfly is \_\_\_\_\_ the bunny and the cat.

Tshisusu tshi \_\_\_\_\_ muvhuda na tshimange.

b The caterpillar is \_\_\_\_\_ the ball.

Shonzha li \_\_\_\_\_ bola

c The bunny is \_\_\_\_\_ the butterfly.

Muvhuda u \_\_\_\_\_ tshisusu.

d The flower is \_\_\_\_\_ the ball.

Dzuvha |i \_\_\_\_\_ bola

e The cat is \_\_\_\_\_ the flower.

Tshimange tshi \_\_\_\_\_ dzuvha.

# Term 1 Lesson 4

## Themo ya 1 Ngudo ya 4

Matching things

U livhanya zwithu

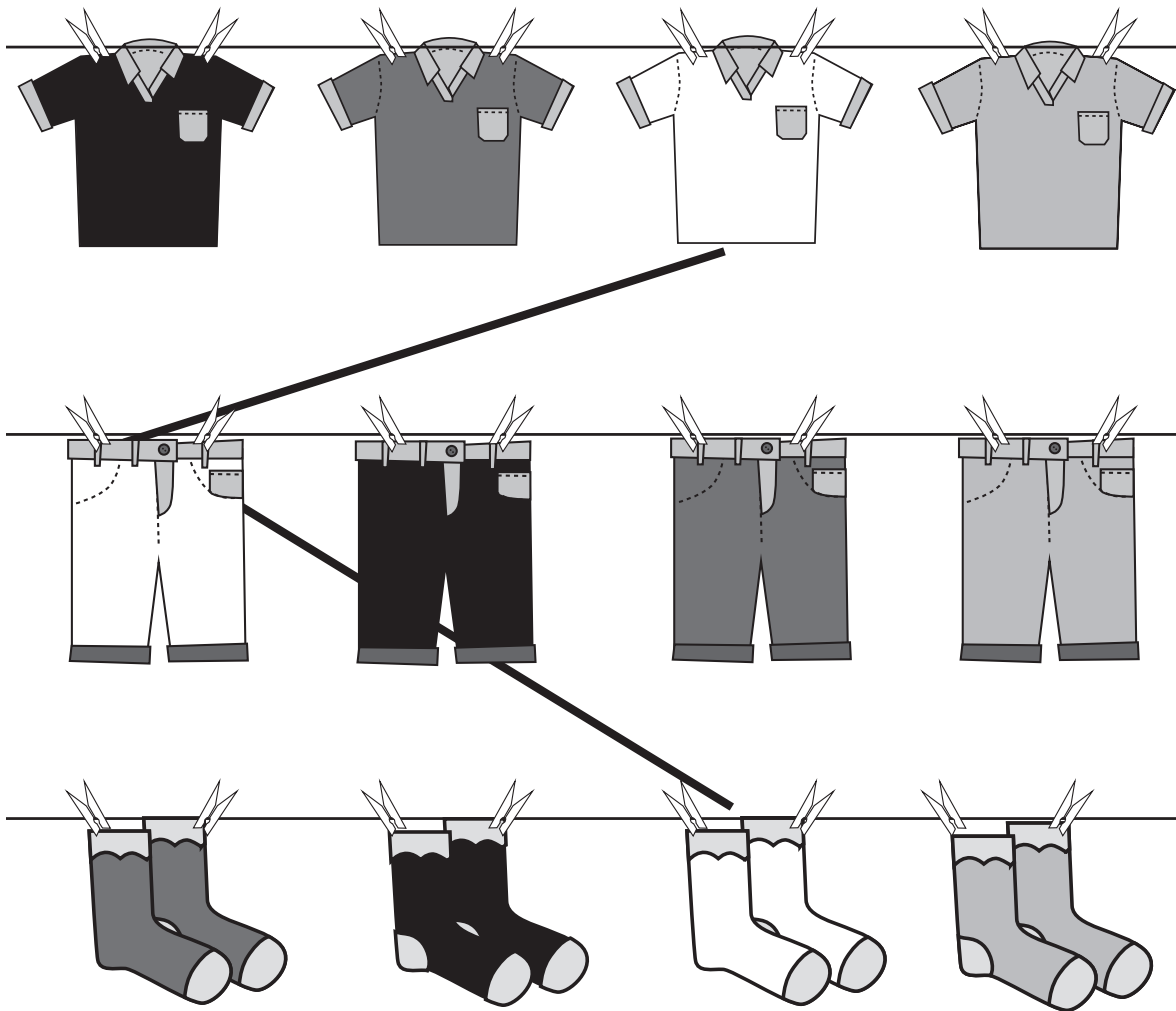

CLASSWORK MUSHUMO WA KILASINI

1 Match one peg to each star

Livhanyani phege nthihi na naledzi inwe na inwe.

2 Draw pictures to match the number of the dots.

Olani zwifanyiso zwi no yelana na tshivhalo tsha zwithoma.



## EXTENSION NYINGANYITO

Draw pictures to match the number of the dots.

Olani zwifanyiso zwi no yelana na tshivhalo tsha zwithoma.



# Term 1 Lesson 5

## Themo ya I Ngudo ya 5

### Consolidation

#### U ṭanganya magudiswa

- 1 Circle all the straight lines.  
Tangedzelani mitalotswititi yọthe.



- 2 Circle all the curves.  
Tangedzelani ngovhe dzọthe.

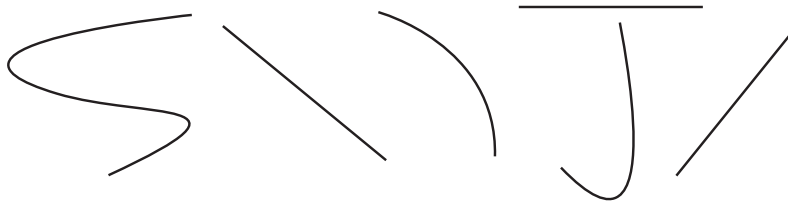

- 3 Trace on the lines.  
Tovhedzelani kha mitalo.

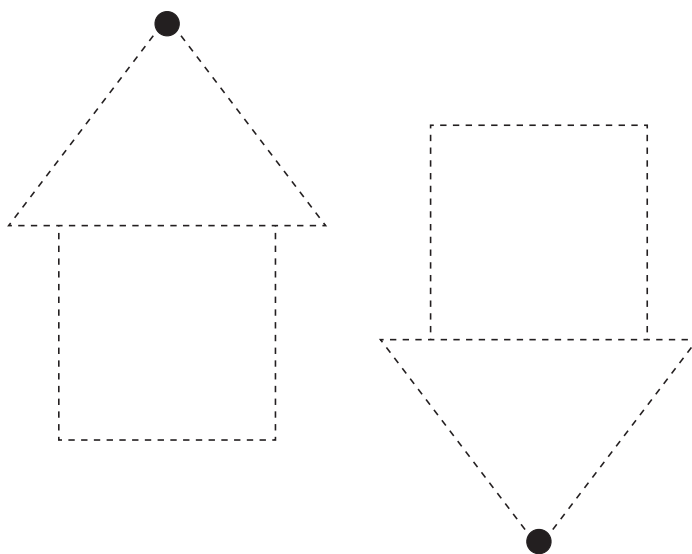

4 Draw lines to match the colours.

Talani mitalo ni tshi livhanya mivhala.

Yellow Ṭaḡa



Blue Lutombo



Pink Pinki



Blue Lutombo

Yellow Ṭaḡa

Pink Pinki

5 Draw lines to match the position of the shapes.

Talani mitalo ni tshi livhanya zwivhumbeo.

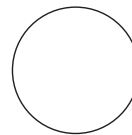
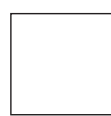
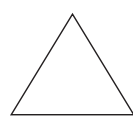
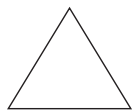
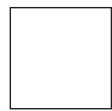
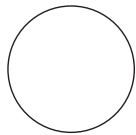

6 Trace the lines.

Tovhedzelani mitalo.



7 On the lines:

Kha mitalo:

- a Draw a circle on the left.  
Olani tshitendeledzi kha tsha monde.
- b Draw a triangle on the right.  
Olani thiraiengele kha tsha u la.
- c Draw a star next to the circle.  
Olani naledzi tsini na tshitendeledzi.
- d Draw a square in between the star and the triangle.  
Olani tshikwea vhukati ha naledzi na thiraiengele.

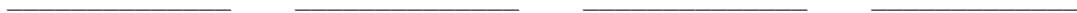

# Term I Lesson 6

## Themo ya I Ngudo ya 6

Numbers

Nomboro



CLASSWORK MUSHUMO WA KILASINI

Match the pictures to the correct number of shaded dots.

Livhanyani zwifanyiso na nomboro yone ya zwithoma zwo swifhadzwaho.

EXTENSION NYINGANYITO

Draw a line to match the pictures to the correct number of shaded dots.

Talani mutalo ni tshi livhanya zwifanyiso na nomboro yone ya zwithoma zwo swifhadzwaho.

Term I Lesson 7

Themo ya I Ngudo ya 7

Assessment

Ulinga

# Term 1 Lesson 8

## Themo ya 1 Ngudo ya 8

Numbers 1 to 5

Nomboro 1 u swika kha 5

### CLASSWORK MUSHUMO WA KILASINI

What do you know about these numbers?

Ni tšalukanya/dzivha zwifhio nga nomboro idzi?

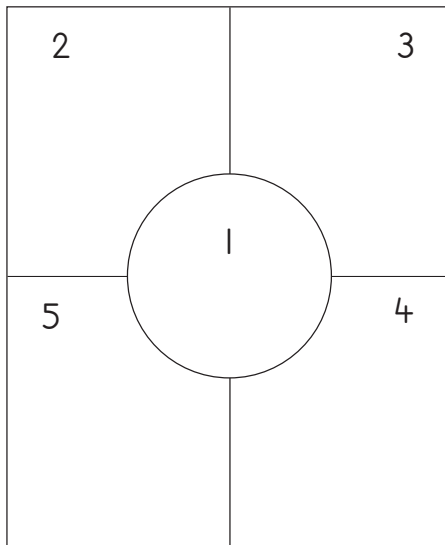

### EXTENSION NYINGANYITO

Draw 1 flower Olani dzuvha 1 a 1	
Draw 2 stars Olani naledzi dza 2	
Draw 3 triangles Olani thiraiengele dza 3	
Draw 4 hearts Olani mbilu dza 4	
Draw 5 faces Olani zwifhatuwo zwa 5	



## Term 1 Lesson 9

## Themo ya 1 Ngudo ya 9

Numbers 1 and 2

Nomboro 1 na 2

## CLASSWORK MUSHUMO WA KILASINI

- 1 Trace the number symbols and number names on the tracing card.  
Tevhedzelani zwiga zwa nomboro na madzina a nomboro kha garaṅa ya u tevhedzela.



1

2
one
thihi
two

# mbili

2 Colour in I shape in each block.

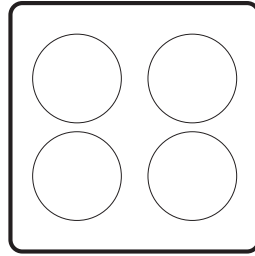
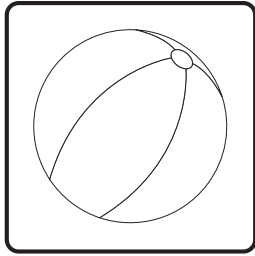
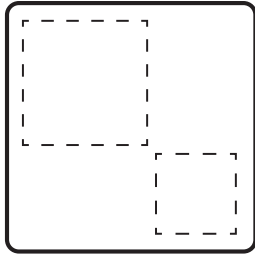
Khalarani tshivhumbeo tsha I kha tshibu, oko tshinwe na tshinwe.



3 Copy and draw 2 more

Edziselani ni ole zwinwe zwa 2.

EXTENSION NYINGANYITO

Colour the shapes:

Khalarani zwivhumbeo:

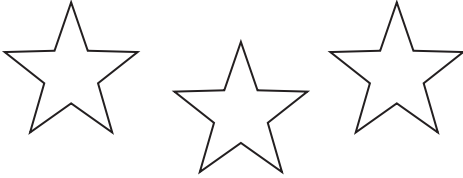
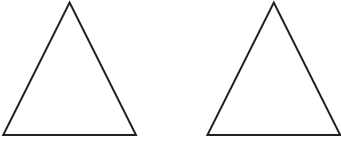
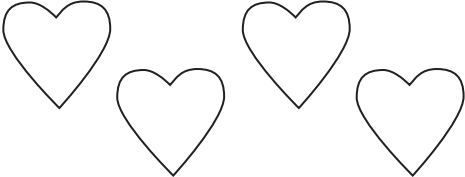
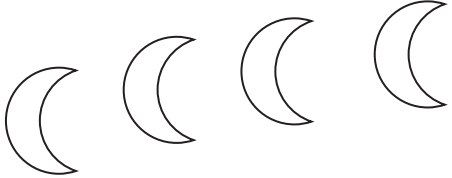
<p>Colour 1 shape Khalarani tshivhumbeo tsha 1</p> 	<p>Colour 1 shape Khalarani tshivhumbeo tsha 1</p> 
<p>Colour 2 shapes Khalarani zwivhumbeo zwa 2</p> 	<p>Colour 2 shapes Khalarani zwivhumbeo zwa 2</p> 

# Term 1 Lesson 10

## Themo ya 1 Ngudo ya 10

### Consolidation

#### U ṭanganya magudiswa

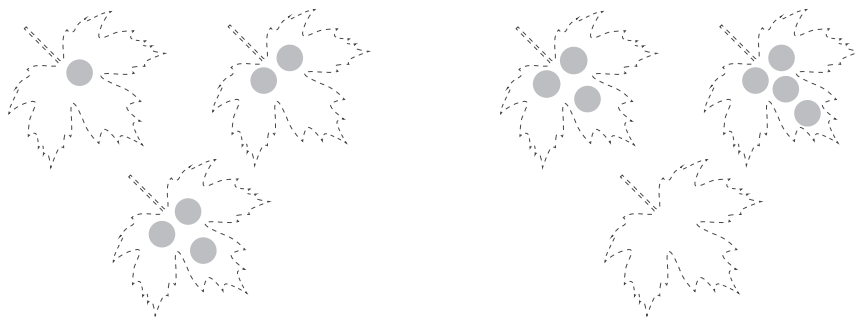

- 1 Draw one more dot on each leaf.

Olani tshithoma tshinwe tshithihi kha ṭari ḷinwe na ḷinwe.





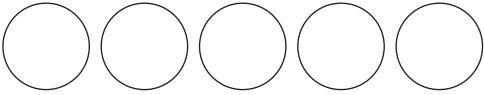
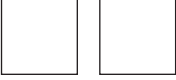
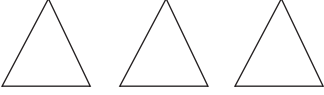

2 Draw one less shape each time.

Zwi oleni hafhu zwo fhungudzea nga tshivhumbeo tshithihi.



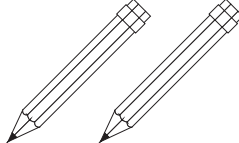

3 Draw dots on the ten frame to match the number of pictures

Olani zwithoma kha fureme ya mahumi ni tshi zwi livhanya na tshivhalo tsha zwifanyiso.

	<table border="1"> <tbody> <tr> <td></td><td></td><td></td><td></td><td></td> </tr> <tr> <td></td><td></td><td></td><td></td><td></td> </tr> </tbody> </table>										
	<table border="1"> <tbody> <tr> <td></td><td></td><td></td><td></td><td></td> </tr> <tr> <td></td><td></td><td></td><td></td><td></td> </tr> </tbody> </table>										
	<table border="1"> <tbody> <tr> <td></td><td></td><td></td><td></td><td></td> </tr> <tr> <td></td><td></td><td></td><td></td><td></td> </tr> </tbody> </table>										
	<table border="1"> <tbody> <tr> <td></td><td></td><td></td><td></td><td></td> </tr> <tr> <td></td><td></td><td></td><td></td><td></td> </tr> </tbody> </table>										
	<table border="1"> <tbody> <tr> <td></td><td></td><td></td><td></td><td></td> </tr> <tr> <td></td><td></td><td></td><td></td><td></td> </tr> </tbody> </table>										

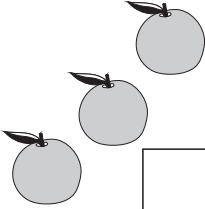
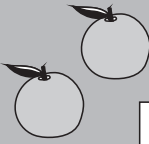
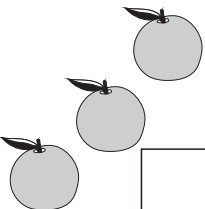
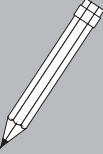
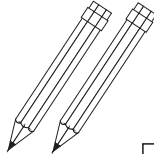
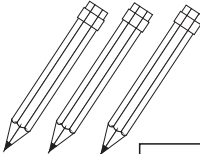
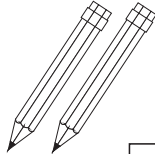

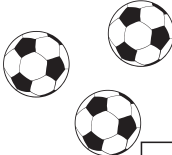

4 Tick the blocks that have **more** than the shaded block.

Itani thiki kha zwibu\oko zwi re na zwi no fhira zwa afho hu re na muvhala.



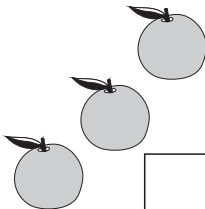
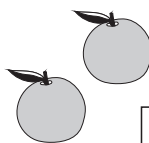
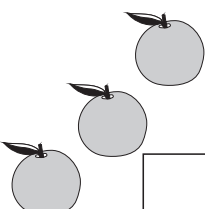
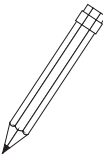
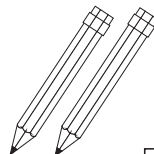
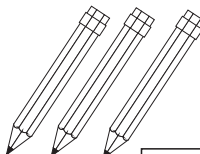
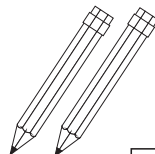



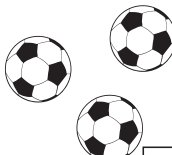

 <input type="checkbox"/>	 <input type="checkbox"/>	 <input type="checkbox"/>	 <input type="checkbox"/>
 <input type="checkbox"/>	 <input type="checkbox"/>	 <input type="checkbox"/>	 <input type="checkbox"/>
 <input type="checkbox"/>	 <input type="checkbox"/>	 <input type="checkbox"/>	 <input type="checkbox"/>









5 Tick the blocks that have the same amount.

Itani thiki kha zwibu\oko zwi re na zwi no e\ena.

 <input type="checkbox"/>	 <input type="checkbox"/>	 <input type="checkbox"/>	 <input type="checkbox"/>
 <input type="checkbox"/>	 <input type="checkbox"/>	 <input type="checkbox"/>	 <input type="checkbox"/>
 <input type="checkbox"/>	 <input type="checkbox"/>	 <input type="checkbox"/>	 <input type="checkbox"/>

# Term I Lesson II

	and na		makes dzi ita	
	and na		makes dzi ita	
	and na		makes dzi ita	

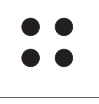
	and na		makes dzi ita	
	and na		makes dzi ita	
	and na		makes dzi ita	

















## Themo ya I Ngudo ya II

Numbers 3 and 4

Nomboro 3 na 4

### CLASSWORK MUSHUMO WA KILASINI

- Trace the number symbols and number names on the tracing card.  
Tevhedzelani zwiga zwa nomboro kha garaṭa ya u tevhedzela.

raru
four
ina

2 Complete the following by making a drawing  
Fhezisani zwi tevhelaho nga u ita nyolo.

3 Colour the shapes:  
Khaḷarani zwivhumbeo:

<p>Colour three shapes Khaḷarani zwivhumbeo zwiraru</p> 	<p>Colour three shapes Khaḷarani zwivhumbeo zwiraru</p> 
<p>Colour four shapes Khaḷarani zwivhumbeo zwiḡa</p> 	<p>Colour four shapes Khaḷarani zwivhumbeo zwiḡa</p> 

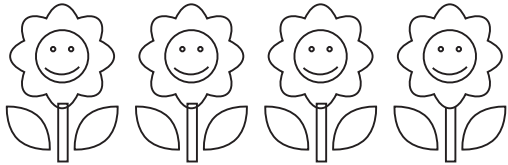
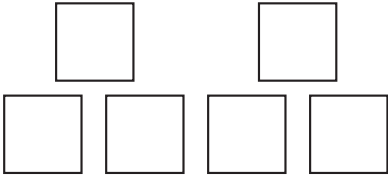
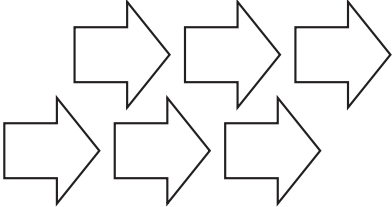
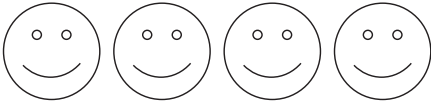



EXTENSION NYINGANYITO

- 1 Write the number 3  
Ñwalani 3 ya tshiga tsha nomboro \_\_\_\_\_
- 2 Write the number 4  
Ñwalani 4 ya tshiga tsha nomboro \_\_\_\_\_
- 3 Write the word three  
Ñwalani ipfinomboro raru \_\_\_\_\_
- 4 Write the word four  
Ñwalani ipfinomboro in̄a . \_\_\_\_\_
5. Draw 3 balls in the block.  
Olani bola dza 3 kha tshibuᵗoko.

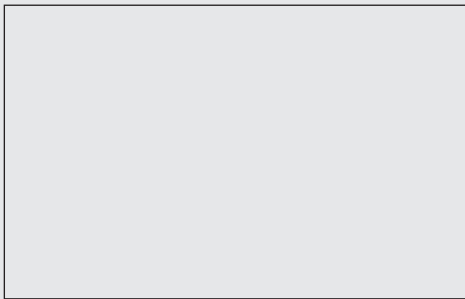

6. Draw 1 more ball in the block.  
Olani in̄we bola ya 1 kha tshibuᵗoko.
7. How many balls are there in the block now?  
Zwino ho no vha na bola nngana kha tshibuᵗoko?

## Term 1 Lesson 12

## Themo ya 1 Ngudo ya 12

Number 5







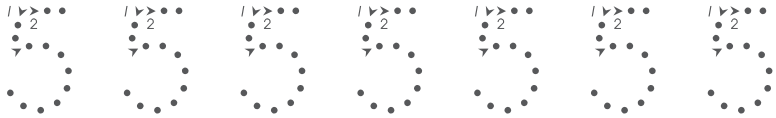











Nomboro ya 5

## CLASSWORK MUSHUMO WA KILASINI

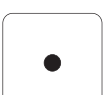
- 1 Trace the number symbols and number names on the tracing cards.  
Tevhedzelani zwiga zwa nomboro kha garaṭa ya u tevhedzela.

5
five
thanu

- 2 Draw the dots and then write a sum:  
 Olani zwithoma ni kone u riwala mbalo:

 	and na	 	make dzi ita	 
 	and na	 	make dzi ita	 
 	and na	 	make dzi ita	 

EXTENSION NYINGANYITO

1 Write the number 5  
Nwalani 5 ya tshiga tsha nomboro

2 Write the word five  
Nwalani ipfinomboro tshanu

3 Colour five objects each time:

Khaḷarani zwithu zwiṭanu tshifhinga tshoṭhe:

Colour five objects  
Khaḷarani zwithu zwiṭanu



Colour five objects  
Khaḷarani zwithu zwiṭanu

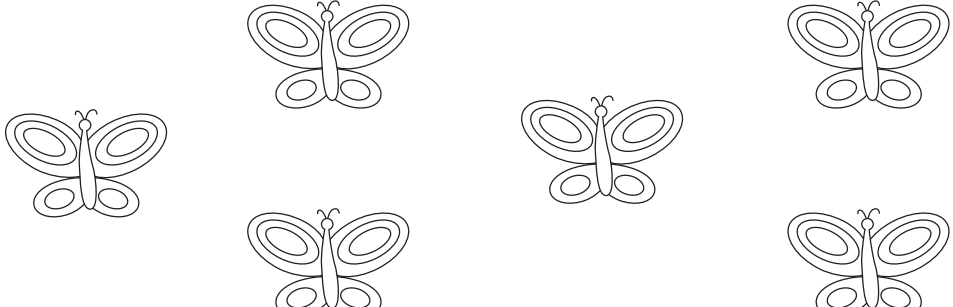

Colour five objects  
Khaḷarani zwithu zwiṭanu

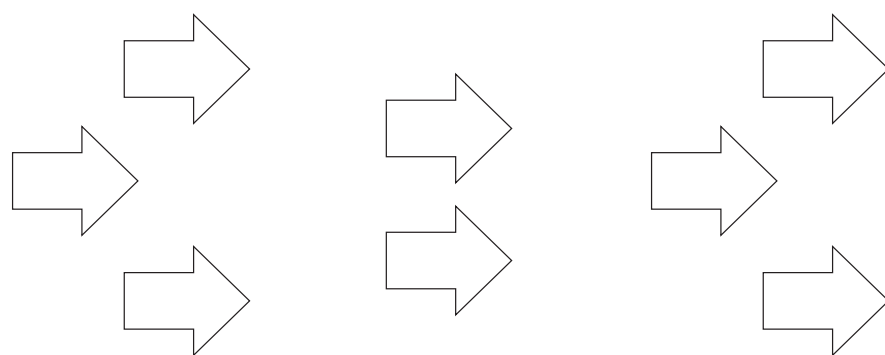

# Term 1 Lesson 13

## Themo ya 1 Ngudo ya 13

Compare and order numbers 1 to 5

U vhambedza na u dubekanya nomboro 1 u swika kha 5

### CLASSWORK MUSHUMO WA KILASINI

- 1 Tick the boxes that have the same number of bottle tops.  
Itani thiki zwibogisini zwine tshivhalo tsha zwithivho tsha lingana.

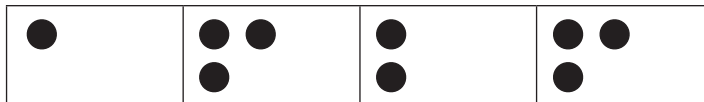

- 2 Tick the boxes that have more bottle tops than the first box.  
Itani thiki zwibogisini zwine tshivhalo tsha zwithivho tsha fhira tsha tshibogisi tsha u thoma.

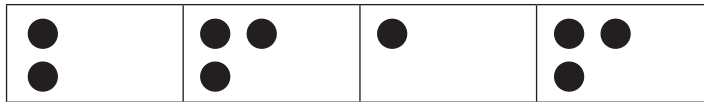

- 3 Tick the boxes that have less bottle tops than the first box.  
Itani thiki zwibogisini zwine tshivhalo tsha zwithivho tsha vha tshituku kha tsha tshibogisi tsha u thoma.

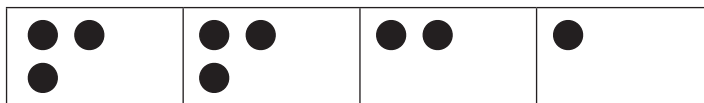

- 4 Draw one more shape on the right-hand side.  
Olani tshivhumbeo tshinwe tshithihi kha tshanda tsha u la.



- 5 Draw one less shape on the right-hand side.  
Fhungudzani nga tshivhumbeo tshithihi ni tshi ole kha tshanda tsha u la.

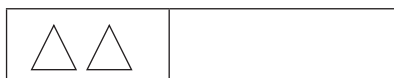





- 6 Write these numbers in the correct order from smallest to biggest.  
 Nwalani nomboro idzi dzi tshi tovhekana nga ngona u bva kha tshukhusesa u ya kha khulwanesesa.

2	1	3
---	---	---

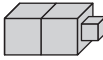
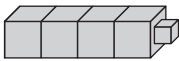
--	--	--

- 7 How many blocks are there?  
 Hu na zwibuloko zwingana?



- 8 Write the number of blocks from the smallest number to the biggest number:  
 Nwalani tshivhalo tsha zwibuloko u bva kha tshukhusesa u ya kha tshihulwanesesa:

--	--	--	--	--

- 9 Show the numbers on the ten frames by drawing dots.  
 Sumbedzani nomboro dzi re kha fureme ya mahumi nga u ita zwithoma.

											
	<table border="1" style="width: 100%; height: 100%; border-collapse: collapse;"> <tr> <td style="width: 20%;"></td> <td style="width: 20%;"></td> <td style="width: 20%;"></td> <td style="width: 20%;"></td> <td style="width: 20%;"></td> </tr> <tr> <td style="width: 20%;"></td> <td style="width: 20%;"></td> <td style="width: 20%;"></td> <td style="width: 20%;"></td> <td style="width: 20%;"></td> </tr> </table>										

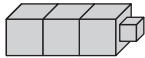

	<table border="1"><tr><td></td><td></td><td></td><td></td><td></td></tr><tr><td></td><td></td><td></td><td></td><td></td></tr></table>										
	<table border="1"><tr><td></td><td></td><td></td><td></td><td></td></tr><tr><td></td><td></td><td></td><td></td><td></td></tr></table>										
	<table border="1"><tr><td></td><td></td><td></td><td></td><td></td></tr><tr><td></td><td></td><td></td><td></td><td></td></tr></table>										
	<table border="1"><tr><td></td><td></td><td></td><td></td><td></td></tr><tr><td></td><td></td><td></td><td></td><td></td></tr></table>										

## EXTENSION NYINGANYITO

- 1 Rewrite these numbers from biggest to smallest.

Ñwalululani nomboro idzi u thoma kha khulwanesa u ya kha t̄hukhusesa ni ole zwithivho u itela u sumbedza nomboro.



1	4	2	5	3					
---	---	---	---	---	--	--	--	--	--

- 2 Rewrite these numbers from smallest to biggest.

Ñwalululani nomboro idzi u thoma kha t̄hukhusesa u ya kha khulwanesesa ni ole zwithivho u itela u sumbedza nomboro.

2	5	3	1	4					
---	---	---	---	---	--	--	--	--	--

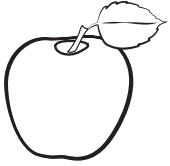
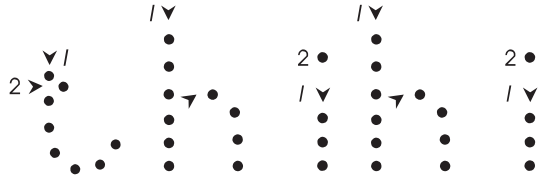
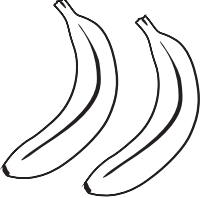
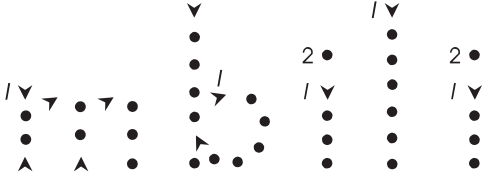
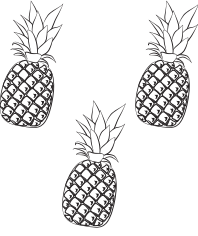
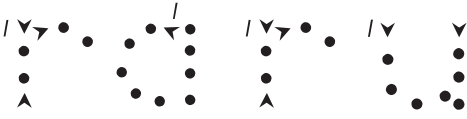
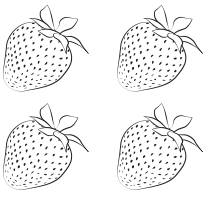
2 Tsvhuzelani ipfinomboro 1a nomboro inwe na inwe.

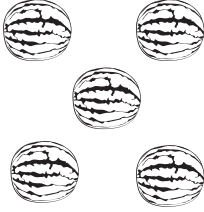
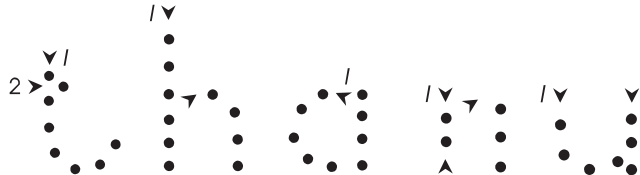
	<p>1</p>	
	<p>2</p>	
	<p>3</p>	
	<p>4</p>	
	<p>5</p>	

# Term 1 Lesson 14

## Themo ya 1 Ngudo ya 14





Numbers 6 to 10

Nomboro 6 u swika kha 10

### CLASSWORK MUSHUMO WA KILASINI

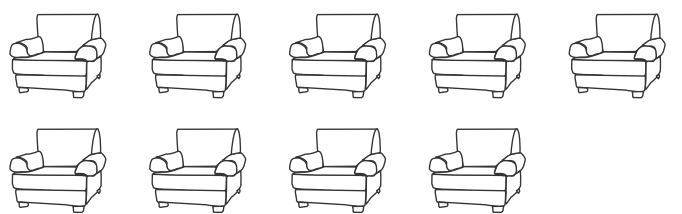
Draw bottle tops on the ten frame to match the pictures.

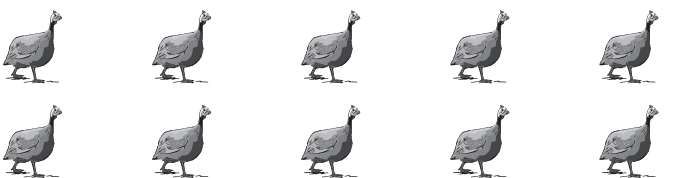
Olani zwithivho kha fureme ya mahumi uri zwi yelane na zwifanyiso.

	<table border="1"> <tbody> <tr> <td></td><td></td><td></td><td></td><td></td> </tr> <tr> <td></td><td></td><td></td><td></td><td></td> </tr> </tbody> </table>										
	<table border="1"> <tbody> <tr> <td></td><td></td><td></td><td></td><td></td> </tr> <tr> <td></td><td></td><td></td><td></td><td></td> </tr> </tbody> </table>										
	<table border="1"> <tbody> <tr> <td></td><td></td><td></td><td></td><td></td> </tr> <tr> <td></td><td></td><td></td><td></td><td></td> </tr> </tbody> </table>										
	<table border="1"> <tbody> <tr> <td></td><td></td><td></td><td></td><td></td> </tr> <tr> <td></td><td></td><td></td><td></td><td></td> </tr> </tbody> </table>										
	<table border="1"> <tbody> <tr> <td></td><td></td><td></td><td></td><td></td> </tr> <tr> <td></td><td></td><td></td><td></td><td></td> </tr> </tbody> </table>										
	<table border="1"> <tbody> <tr> <td></td><td></td><td></td><td></td><td></td> </tr> <tr> <td></td><td></td><td></td><td></td><td></td> </tr> </tbody> </table>										

### EXTENSION NYINGANYITO

- 1 Draw 6 bananas.  
Olani miomva ya 6.
  
- 2 Draw 7 trees.  
Olani miri ya 7.
  
- 3 Draw 8 rainbows.  
Olani misengavhadzimu ya 8.
  
- 4 Draw 9 suns.  
Olani maguvha a 9.
  
- 5 Draw 10 clouds.  
Olani makole a 10.

## Term I Lesson 15





## Themo ya I Ngudo ya 15

## Consolidation

## U ṭanganya magudiswa

- 1 Count the pictures and circle the correct number symbol.

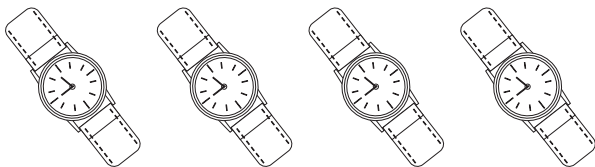
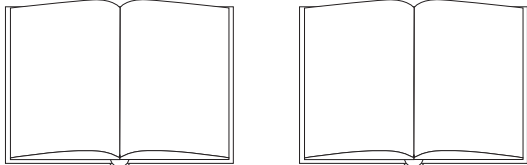
Vhalani zwifanyiso ni tangedzele tshiga tsha nomboro tshone.

	1	2	3	4	5	6	7
	1	2	3	4	5	6	7
	1	2	3	4	5	6	7
	1	2	3	4	5	6	7
	1	2	3	4	5	6	7

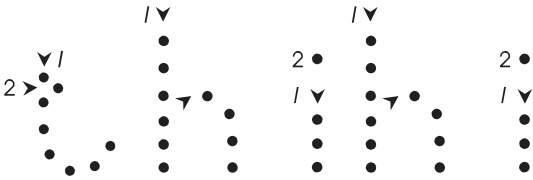
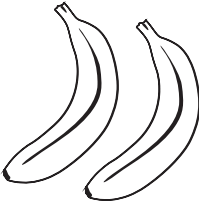
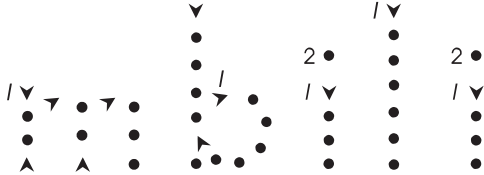
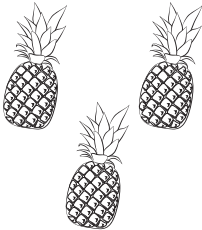
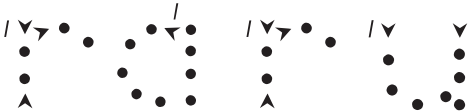
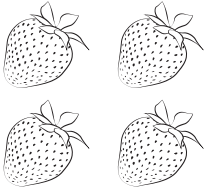
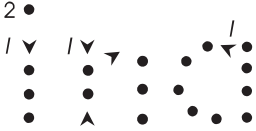
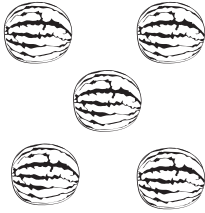
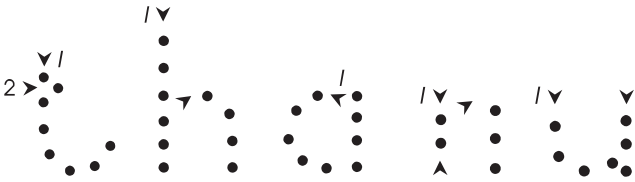

2 Trace the word for each of the numbers.

Tevhedzelani ipfinomboro la nomboro inwe na inwe.



	<p>1</p>	
	<p>2</p>	
	<p>3</p>	
	<p>4</p>	
	<p>5</p>	



3 Count the pictures and fill in the missing numbers.

Vhalani zwifanyiso ni n'wale nomboro dzi no khou t̄ahela.

	and na		2 and 2 make 4 2 na 2 dzi ita 4
<input type="text" value="2"/>		<input type="text" value="2"/>	















	and na		2 and 1 make 2 na 1 dzi ita
<input type="text" value="2"/>		<input type="text" value="2"/>	

	and na		3 and 2 make 3 na 2 dzi ita
<input type="text" value="2"/>		<input type="text" value="2"/>	

	and na		2 and 3 make 2 na 3 dzi ita
<input type="text" value="2"/>		<input type="text" value="2"/>	

4 Draw the total number of dots each time.

Olani tshivalogutše tsha zwithoma hoṭhe.

	and na		make dzi ita	
	and na		make dzi ita	
	and na		make dzi ita	
	and na		make dzi ita	
	and na		make dzi ita	
	and na		make dzi ita	
	and na		make dzi ita	

5 Write the numbers from smallest to biggest.

Nwalani nomboro u thoma kha ṭhukhusesa u swika kha khulwanesesesa

3, 1, 2	
5, 1, 4	
4, 1, 2	
3, 2, 5	
1, 4, 3	



Term I Lesson 16

Themo ya I Ngudo ya 16

Assessment

Ulinga

# Term 1 Lesson 17

## Themo ya 1 Ngudo ya 17

Numbers 6 and 7

Nomboro 6 na 7

### CLASSWORK MUSHUMO WA KILASINI

- 1 Trace the number symbols and number names on the tracing card.  
Tevhedzelani zwiga zwa nomboro kha garaṅa ya u tevhedzela.

6 6 6 6 6 6 6
6
7 7 7 7 7 7 7
7
six
rathi
seven
sumbe

2 Make 6 by drawing:

Itani zwa 6 nga u tou ola.

●	and na		make dzi ita	● ● ● ● ● ●
	and na	● ● ●	make dzi ita	● ● ● ● ● ●
● ●	and na		make dzi ita	● ● ● ● ● ●

3 Make 7 by drawing:

Itani zwa 7 nga u tou ola.

● ● ● ●	and na		make dzi ita	● ● ● ● ● ● ●
	and na	● ● ● ● ●	make dzi ita	● ● ● ● ● ● ●
● ● ●	and na		make dzi ita	● ● ● ● ● ● ●
	and na	● ● ● ● ● ●	make dzi ita	● ● ● ● ● ● ●
● ●	and na		make dzi ita	● ● ● ● ● ● ●

EXTENSION NYINGANYITO

1. Write the number symbol 6  
Ñwalani 6 ya tshiga tsha nomboro
2. Write the number symbol 7  
Ñwalani 7 ya tshiga tsha nomboro
3. Write the word six  
Ñwalani ipfinomboro rathi \_\_\_\_\_
4. Write the word seven  
Ñwalani ipfinomboro sumbe \_\_\_\_\_
5. Draw six more triangles.  
Olani dziñwe thiraiengele dza rathi.



6. Draw seven more triangles.  
Olani dziñwe thiraiengele dza sumbe.

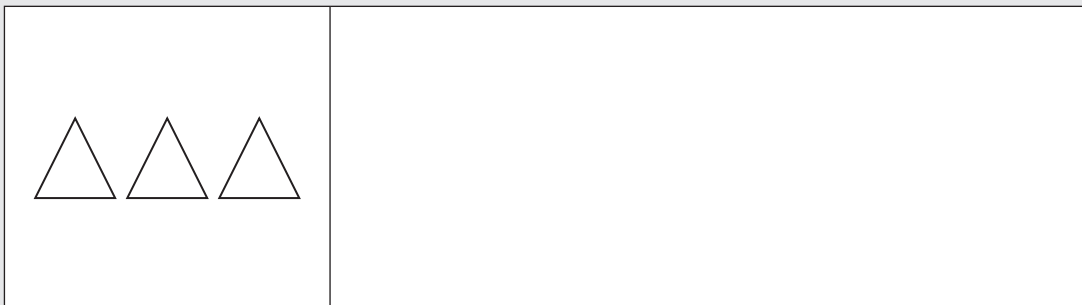

## Term 1 Lesson 18

## Themo ya 1 Ngudo ya 18

Numbers 8 and 9

Nomboro 8 na 9

## CLASSWORK MUSHUMO WA KILASINI

- 1 Trace the number symbols and number names on the tracing card.  
Tevhedzelani zwiga zwa nomboro kha garaṭa ya u tevhedzela.

8	8	8	8	8	8	8
8						
9	9	9	9	9	9	9
9						
eight						
malo						
nine						
tahe						

2 Make 8 by matching (draw a line):

Vhumbani zwa 8 nga u livhanya (talani mutalo)

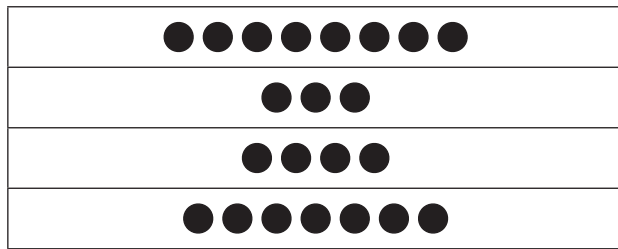
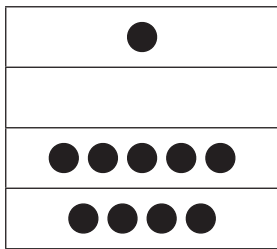

3 Make 9 by matching (draw a line):

Vhumbani zwa 9 nga u livhanya (talani mutalo)

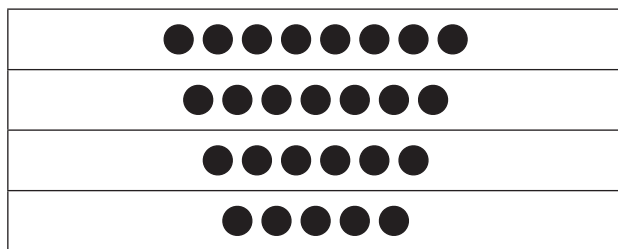
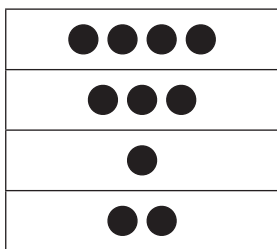

EXTENSION NYINGANYITO

1 Write the number symbol 8.

Ñwalani 8 ya tshiga tsha nomboro. \_\_\_\_\_

2 Write the number symbol 9.

Ñwalani 9 ya tshiga tsha nomboro. \_\_\_\_\_

3 Write the word eight.

Ñwalani ipfinomboro malo. \_\_\_\_\_

4 Write the word nine.

Ñwalani ipfinomboro t̄ahe. \_\_\_\_\_

5 Draw eight more shapes.

Olani zwivhumbeo dziñwe hafhu zwa malo.



6 Draw nine more shapes.

Olani zwivhumbeo dziñwe hafhu zwa t̄ahe.



## Term 1 Lesson 19

## Themo ya 1 Ngudo ya 19

Number 10

Nomboro ya 10

## CLASSWORK MUSHUMO WA KILASINI

- Trace the number symbols and number names on the tracing card.  
Tevhedzelani zwiga zwa nomboro kha garaṅa ya u tevhedzela.

10 10 10 10 10

10

ten

fumi

EXTENSION NYINGANYITO

Fill in the missing number symbols, number names, and pictures.

Nwalani zwiga zwa nomboro, madzinambalo na zwifanyiso zwi no khou t̄ahela.

a	1		
b			
c		three raru	
d	4		
e		five t̄hanu	
f	6		
g			
h		eight malo	
i	9		
j		ten fumi	



## Term I Lesson 20

## Themo ya I Ngudo ya 20

## Consolidation

## U ṭanganya magudiswa



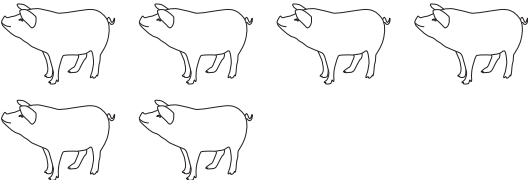
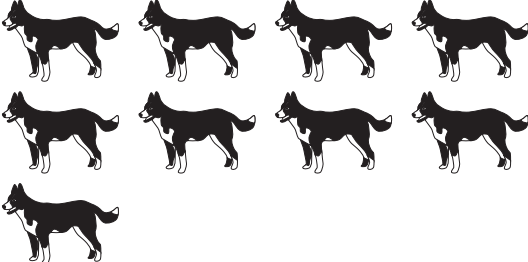
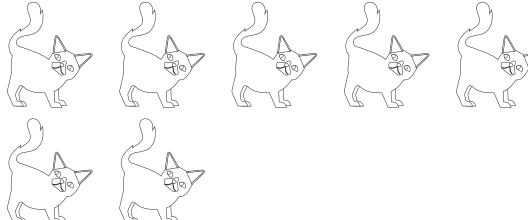
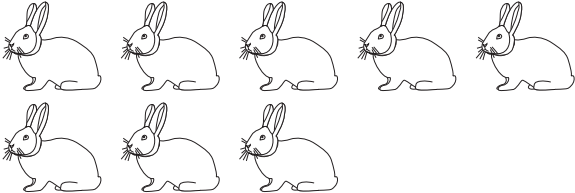

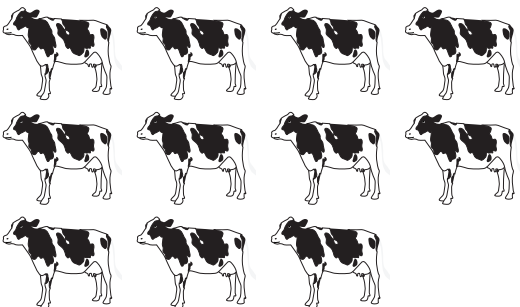
- I Count the pictures and circle the correct number symbol.  
Vhalani zwifanyiso ni tangedzele tshiga tsha nomboro tshone.

	5	6	7	8	9	10
	5	6	7	8	9	10
	5	6	7	8	9	10
	5	6	7	8	9	10

	5	6	7	8	9	10
---	---	---	---	---	---	----

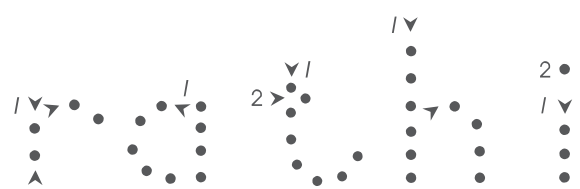
2 Trace the word for each of the numbers.

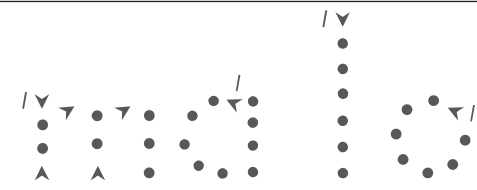
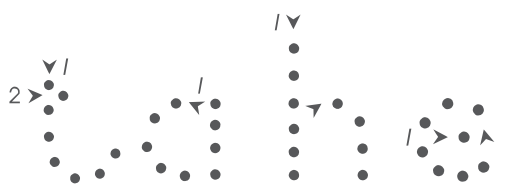
Tevhedzelani ipfinomboro la nomboro inwe na inwe.

6	
7	
8	
9	
10	

Tevhedzelani ipfinomboro la nomboro inwe na inwe.

6	
7	
8	
9	
10	

- 3 Draw dots on the ten frame to match the numbers.  
Olani zwithoma kha fureme ya mahumi ni tshi livhanya nomboro.

6

9

7

10

- 4 Count the black dots and write the number.  
 Vhalani zwithoma zwitswu ni ñwale nomboro.

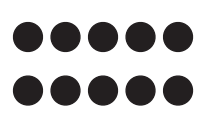
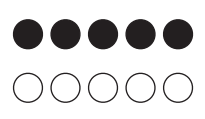
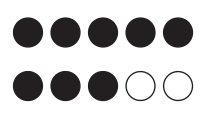
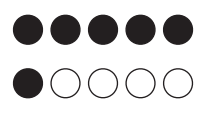
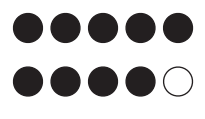
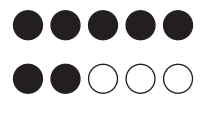
- 5 Write the numbers from smallest to biggest.

Nwalani nomboro u bva kha ṭhukhusesa u ya kha khulwanesesa.

3	5	8	1	7	4	10	6	2	9

- 6 Write the numbers from biggest to smallest.

Nwalani nomboro u bva kha khulwanesesa u ya kha ṭhukhusesa.

6	1	10	8	3	5	7	2	9	4

# Term I Lesson 21

## Themo ya I Ngudo ya 21

Assessment

Ulinga

## Term 1 Lesson 22

## Themo ya I Ngudo ya 22

Number bonds of 6 and 7

Mbumbanomboro dza 6 na 7

## CLASSWORK MUSHUMO WA KILASINI

- 1 Draw dots in the ten frames to make 6, then fill in the missing numbers.  
Olani zwithoma kha fureme dza mahumi uri ni vhumbe 6, ni kone u dzhenisa nomboro dzi no khou tshela.

	2	and na	<input type="text"/>	make dzi ita	6
	5	and na	<input type="text"/>	make dzi ita	6
	3	and na	<input type="text"/>	make dzi ita	6
	6	and na	<input type="text"/>	make dzi ita	6

2 Draw dots in the ten frame to make 7, then fill in the missing numbers.

Olani zwithoma kha fureme dza mahumi uri ni vhumbe 7, ni kone u dzhenisa nomboro dzi no khou tshela.

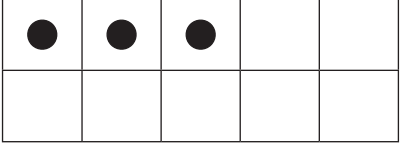
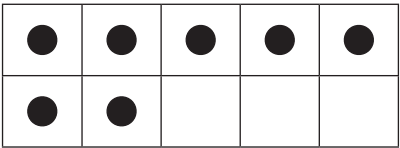
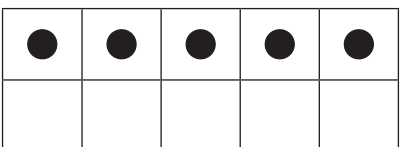
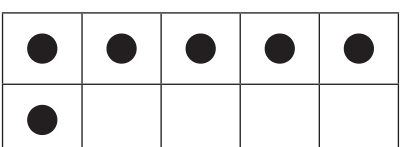
	3 and na <input type="text"/> make dzi ita <input type="text"/>
	7 and na <input type="text"/> make dzi ita <input type="text"/>
	5 and na <input type="text"/> make dzi ita <input type="text"/>
	6 and na <input type="text"/> make dzi ita <input type="text"/>

EXTENSION NYINGANYITO

1 Draw dots to show how you can make 6.

Olani zwithoma ni tshi sumbedza kuvhumbelwe kwa 6.

<input type="text"/>	and na	<input type="text"/>	make dzi ita	6
<input type="text"/>	and na	<input type="text"/>	make dzi ita	6
<input type="text"/>	and na	<input type="text"/>	make dzi ita	6

2 Draw dots to show how you can make 7.

Olani zwithoma ni tshi sumbedza kuvhumbelwe kwa 7.

<input type="text"/>	and na	<input type="text"/>	make dzi ita	7
<input type="text"/>	and na	<input type="text"/>	make dzi ita	7
<input type="text"/>	and na	<input type="text"/>	make dzi ita	7



## Term 1 Lesson 23

## Themo ya I Ngudo ya 23

Number bonds of 8 and 9

Mbumbanomboro dza 8 na 9

## CLASSWORK MUSHUMO WA KILASINI

- 1 Draw dots in the ten frame to make 8, then fill in the missing numbers.  
Olani zwithoma kha fureme dza mahumi uri ni vhumbe 8, ni kone u dzhenisa nomboro dzi no khou țahela.

	7	and	<input type="text"/>	make	8
		na		dzi ita	
	4	and	<input type="text"/>	make	8
		na		dzi ita	
	2	and	<input type="text"/>	make	8
		na		dzi ita	
	5	and	<input type="text"/>	make	8
		na		dzi ita	

- 2 Draw dots in the ten frame to make 9, then fill in the missing numbers.  
Olani zwithoma kha fureme dza mahumi uri ni vhumbe 9, ni kone u dzhenisa nomboro dzi no khou țahela.

	6	and	<input type="text"/>	make	9
		na		dzi ita	
	1	and	<input type="text"/>	make	9
		na		dzi ita	
	4	and	<input type="text"/>	make	9
		na		dzi ita	
	7	and	<input type="text"/>	make	9
		na		dzi ita	

EXTENSION NYINGANYITO

1 Draw dots to show how you can make 8.

Olani zwithoma ni tshi sumbedza kuvhumbelwe kwa 6.

	and na		make dzi ita	8
	and na		make dzi ita	8
	and na		make dzi ita	8

2 Draw dots to show how you can make 9.

Olani zwithoma ni tshi sumbedza kuvhumbelwe kwa 7.

	and na		make dzi ita	9
	and na		make dzi ita	9
	and na		make dzi ita	9

# Term 1 Lesson 24

## Themo ya I Ngudo ya 24

Number bonds of 10

Mbumbanomboro dza 10



### CLASSWORK MUSHUMO WA KILASINI

- 1 Draw dots in the ten frame to make up 10, then fill in the missing numbers.  
Olani zwithoma kha fureme dza mahumi uri ni vhumbe 10, ni kone u dzhenisa nomboro dzi no khou tshela.

EXTENSION NYINGANYITO

Show the numbers with your fingers, then trace and write the number symbol.

Sumbedzani nomboro nga minwe yaṅu, ni kone u tevhedzela na u riwala tshiga tsha nomboro.

	1	
	2	
	3	
	4	
	5	
	6	
	7	
	8	
	9	
	10	

## Term I Lesson 25

## Themo ya I Ngudo ya 25

## Consolidation

## U ṭanganya magudiswa

- 1 How many more shapes to make 10?  
10 i vhumbiwa nga zwivhumbeo zwiñwe hafhu zwingana?

--	--	--	--	--	--

- 2 How many more shapes to make 9?  
9 i vhumbiwa nga zwivhumbeo zwiñwe hafhu zwingana?

--	--	--	--	--	--

- 3 How many more shapes to make 6?  
6 i vhumbiwa nga zwivhumbeo zwiñwe hafhu zwingana?

--	--	--	--	--	--

- 4 How many more shapes to make 8?  
8 i vhumbiwa nga zwivhumbeo zwiñwe hafhu zwingana?

--	--	--	--	--	--

- 5 How many more shapes to make 7?  
7 i vhumbiwa nga zwivhumbeo zwiñwe hafhu zwingana?

--	--	--	--	--	--









6 Solve the following: you can make a drawing to help you.

Tandululani zwi tevhelaho: ni nga ita nyolo ya u ni thusa.

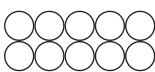
- a One more than 9 is   
 Khulwane kha 9 nga nthihi ndi
- b One more than 7 is   
 Khulwane kha 7 nga nthihi ndi
- c Two more than 6 is   
 Khulwane kha 8 nga mbili ndi
- d Two more than 8 is   
 Khulwane kha 8 nga mbili ndi

7 Complete the table for each number:

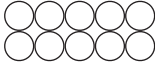
Fhedzisani thebulu ya nomboro inwe na inwe:

Number symbol Tshiga tsha nomboro	10 frame Fureme ya mahumi	Number name	Dzinambalo
6			
		three	raru
7		seven	sumbe
			
10			
		eight	malo
4			
		nine	tahe
0			

## Term 1 Lesson 26

## Themo ya I Ngudo ya 26

Number bonds 2 to 10

Mbumbanomboro 2 u swika kha 10

## CLASSWORK MUSHUMO WA KILASINI

Use your bottle tops to work out the missing numbers. Write them in the empty blocks.

Shumisani zwithivho zwanu zwa mabogelo kha u wana nomboro dzi no khoutahela. Dzi nwaleni kha zwibujoko zwi si na tshithu.

1

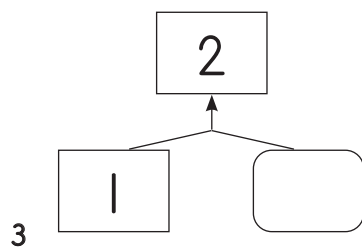

2

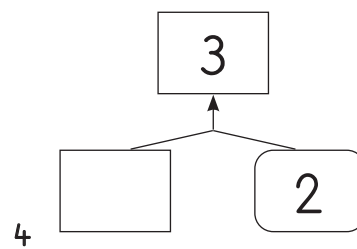

3

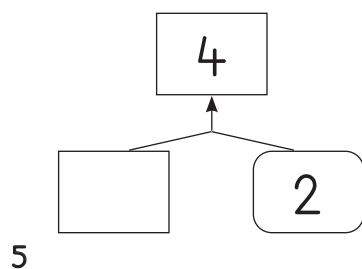

4

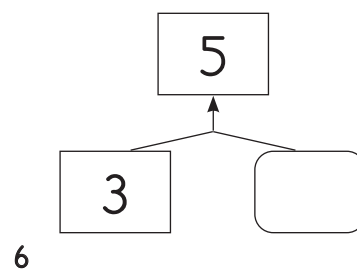

5

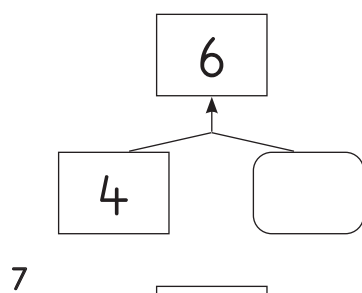

6

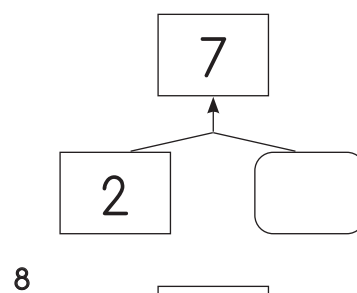

7

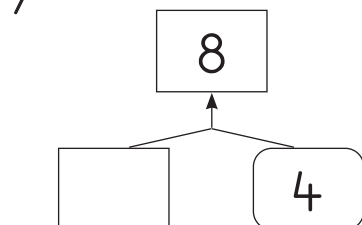

8

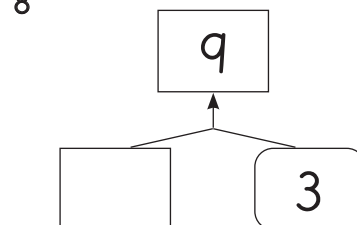

9

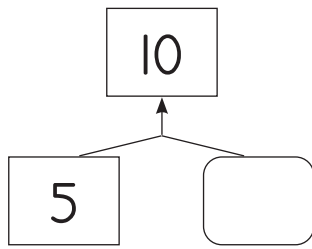

10

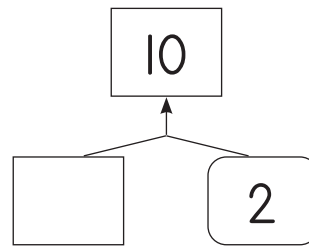

EXTENSION NYINGANYITO

Write the missing numbers in the empty blocks.

Ñwalani nomboro dzi no khou t̄ahela kha zwibuḷoko zwi si na tshithu.

1

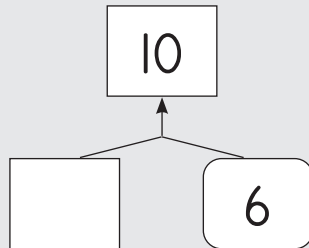

2

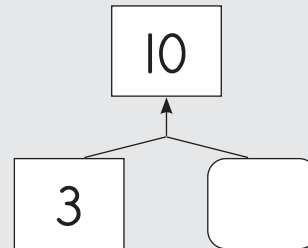

3

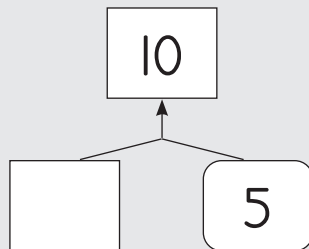

4

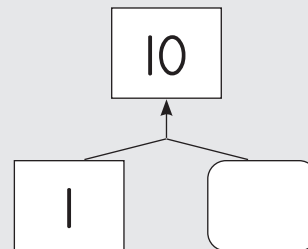



# Term I Lesson 27

## Themo ya I Ngudo ya 27

Assessment

Ulinga

## Term I Lesson 28

## Themo ya I Ngudo ya 28

Compare and order numbers 1 to 10

U vhambedza na u dubekanya nomboro 1 u swika kha 10

## CLASSWORK MUSHUMO WA KILASINI

- 1 Compare the numbers:  
Vhambedzani nomboro.

4 and 8	_____ is more than _____ by _____
4 na 8	_____ ndi khulwane kha _____ nga _____
6 and 9	_____ is more than _____ by _____
6 na 9	_____ ndi khulwane kha _____ nga _____
7 and 5	_____ is more than _____ by _____
7 na 5	_____ ndi khulwane kha _____ nga _____
10 and 3	_____ is more than _____ by _____
10 na 3	_____ ndi khulwane kha _____ nga _____

- 2 Compare the numbers:  
Vhambedzani nomboro:

5 <sub>and</sub> 8	_____ is less than _____ by _____
5 <sub>na</sub> 8	_____ ndi ṭhukhu kha _____ nga _____
6 <sub>and</sub> 4	_____ is less than _____ by _____
6 <sub>na</sub> 4	_____ ndi ṭhukhu kha _____ nga _____
10 <sub>and</sub> 5	_____ is less than _____ by _____
10 <sub>na</sub> 5	_____ ndi ṭhukhu kha _____ nga _____
3 <sub>and</sub> 7	_____ is less than _____ by _____
3 <sub>na</sub> 7	_____ ndi ṭhukhu kha _____ nga _____

EXTENSION NYINGANYITO

- 1 Draw a triangle around the smallest number and a circle around the biggest number.

Olani thiraiengele u mona na nomboro ṭhukhusesa na tshitendeledzi u mona na nomboro khulwanesesa.

7	4	3	9	10	8	5	1	6
---	---	---	---	----	---	---	---	---

- 2 Write the numbers from the smallest to the biggest on the number line.

Nwalani nomboro idzi kha mutalombalo u bva kha ṭhukhusesa u swika kha khulwanesesa.

10      6      8      7      9      5



## Term I Lesson 29

## Themo ya I Ngudo ya 29

Concept of zero

Muhumbulo wa zero/pumu

## CLASSWORK MUSHUMO WA KILASINI

- 1 Trace the number symbol and number name zero on the tracing card.  
Tevhedzelani tshiga tsha nomboro na dzinambalo zero kha garaṭa ya u tevhedzela.

0	0	0	0	0	0	0
0						
zero	zero	zero				
zero/pumu						

- 2 Draw dots:  
Olani zwithoma:

0	and na		make dzi ita	2
0	and na		make dzi ita	9
0	and na		make dzi ita	6
0	and na		make dzi ita	4
0	and na		make dzi ita	10

3 Fill in the missing numbers:

Nwalani nomboro dzi no khou t̄ahela:



10 number lines for filling in missing numbers:

- Line 1: 1, 2, 3, 4, 5, 6, 7, 8, 9, 10
- Line 2: 1, 2, 3, , 5, 6, 7, 8, 9, 10
- Line 3: 1, 2, 3, , , 6, 7, 8, 9, 10
- Line 4: 1, 2, , 4, 5, 6, , 8, , 10
- Line 5: 1, 2, 3, , 5, 6, 7, , , 10
- Line 6: , 2, , 4, 5, , 7, 8, , 10
- Line 7: , 2, 3, 4, 5, 6, 7, , 9,
- Line 8: , , , , , , , ,
- Line 9: 10, 9, 8, 7, 6, 5, , , ,

## EXTENSION NYINGANYITO

Fill in the missing numbers:

5 and 0 make \_\_\_\_\_

7 and 0 make \_\_\_\_\_

0 and 3 make \_\_\_\_\_

10 and 0 make \_\_\_\_\_

0 and 8 make \_\_\_\_\_

Ñwalani nomboro dzi no khou t̄ahela:

5 na 0 dzi ita \_\_\_\_\_

7 na 0 dzi ita \_\_\_\_\_

0 na 3 dzi ita \_\_\_\_\_

10 na 0 dzi ita \_\_\_\_\_

0 na 8 dzi ita \_\_\_\_\_

## Term I Lesson 30

## Themo ya I Ngudo ya 30

## Consolidation

## U ṭanganya magudiswa

- 1 Write the number to make the number in the top box.

Ñwalani nomboro vhumba nomboro i re tshibogisini tsha n̄tha.

1

10	
8	

2

7	
	3

3

5	
1	

4

9	
	4

5

3	
2	

6

6	
	3

7

2	
	1

8

4	
	4



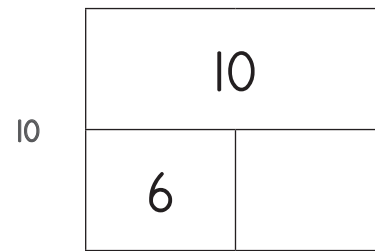
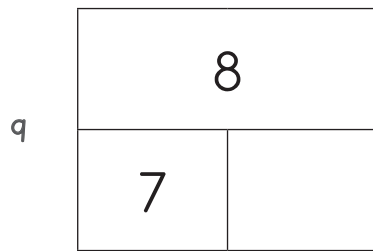

2 Write the answer in the block.

Nwalani phindulo tshukhu.

	Which is smaller? Ndi ifhio i re tshukhu?	Answer Phindulo		Which is bigger? Ndi ifhio i re khulwane?	Answer Phindulo
1	1 or kana 9?		6	10 or kana 9?	
2	7 or kana 5?		7	6 or kana 8?	
3	3 or kana 10?		8	5 or kana 1?	
4	4 or kana 6?		9	4 or kana 0?	
5	8 or kana 2?		10	2 or kana 7?	

- 3 Write these numbers in order from the biggest to the smallest.  
Nwalani nomboro idzi u bva kha khulwanesesa u ya kha thukhusesa.

		Answer Phindulo
1	0, 8, 2, 10, 7, 3	
2	5, 2, 7, 9, 6, 3	
3	0, 4, 10, 6, 9	
4	6, 2, 7, 9, 1, 3	
5	9, 2, 4, 8, 3, 0	
6	8, 5, 2, 4, 9	
7	0, 6, 3, 9, 4	
8	10, 8, 3, 2, 7	
9	0, 8, 6, 3, 1, 9	

10	6, 5, 1, 9, 10	
----	----------------	--

## Term 1 Lesson 31

### Themo ya 1 Ngudo ya 31

Counting forwards and backwards

U vhalela phanda na murahu

#### CLASSWORK MUSHUMO WA KILASINI

- 1 Complete the pattern by colouring the multiples of 2.  
Fhedzisani phetheni nga u khalara nyandiso dza 2.

1	2	3	4	5	6	7	8	9	10
---	---	---	---	---	---	---	---	---	----

- 2 Complete the number line:  
Fhedzisani mutalombalo:



- 3 Draw hops on a number line to show 2, 4, 6, 8  
Olani mithamuwo kha mutalombalo ni tshi sumbedza 2, 4, 6, 8



- 4 Draw hops on a number line to show 10, 8, 6, 4  
Olani mithamuwo kha mutalombalo ni tshi sumbedza 10, 8, 6, 4

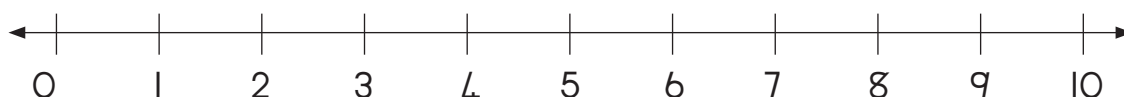

EXTENSION NYINGANYITO

- 1 Write the multiples of 2. Start at 4.  
Nwalani nyandiso dza 2. Thomani kha 4.

- 
- 2 Draw hops on a number line to show 4, 6, 8, 10  
Olani mithamuwo kha mutalombalo ni tshi sumbedza 4, 6, 8, 10

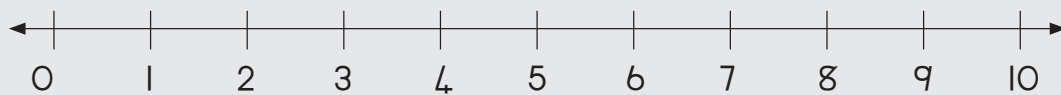

# Term 1 Lesson 32

## Themo ya I Ngudo ya 32

Number patterns

Phetheni dza nomboro

I Hundred board activity.

Nyito ya bodo ya dana.

1	2	3	4	5	6	7	8	9	10
11	12	13	14	15	16	17	18	19	20
21	22	23	24	25	26	27	28	29	30
31	32	33	34	35	36	37	38	39	40
41	42	43	44	45	46	47	48	49	50
51	52	53	54	55	56	57	58	59	60
61	62	63	64	65	66	67	68	69	70
71	72	73	74	75	76	77	78	79	80
81	82	83	84	85	86	87	88	89	90
91	92	93	94	95	96	97	98	99	100

- 2 Draw a line to the matching number. Then complete two more hops.  
 Talani mutalo ni tshi livhanya nomboro. Ni kone u fhedzisa mithamuwo miñwe mivhili.

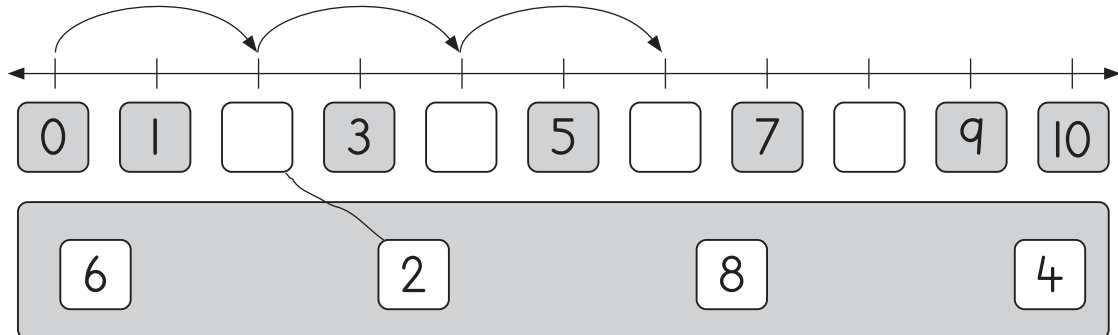

- 3 Complete the pattern by colouring the numbers.  
 Fhedzisani phetheni nga u khalara nomboro.



- 4 Choose your own numbers to write in the blocks and show the pattern on the number lines.  
 Dinangeleni nomboro dzine na go ñwala zwibu okoni ni sumbedze phetheni dzi re kha mitalombalo.

- a Pattern of 1s.  
 Phetheni ya dzil.

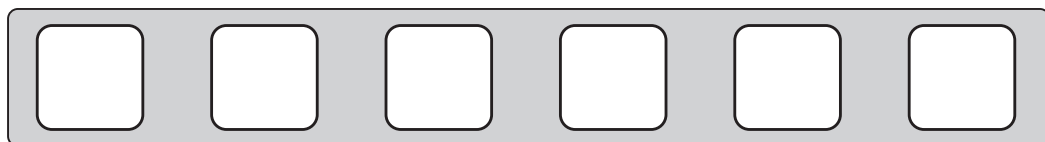

- b Pattern of 2s.  
 Phetheni ya dzi2.

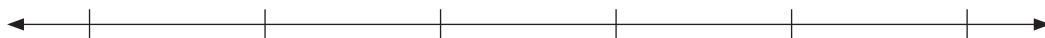
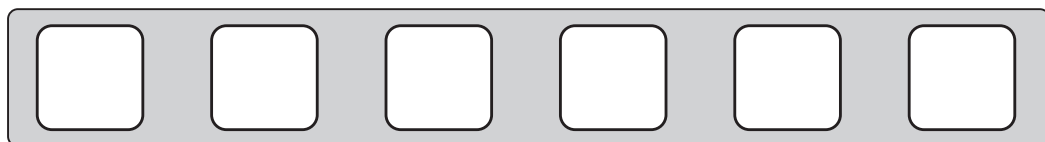

## EXTENSION NYINGANYITO

- 1 Choose your own numbers to write in the blocks and show the pattern on the number lines.

Dinangeleni nomboro dzine na do n'wala zwibu\okoni ni sumbedze phetheni dzi re kha mitalombalo.

- a Pattern of 1s

Phetheni ya dzi1.

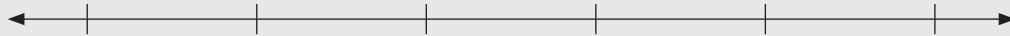
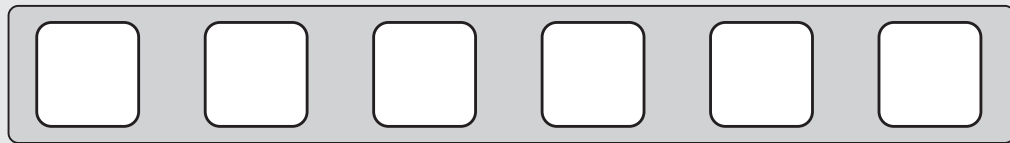

- b Pattern of 2s

Phetheni ya dzi2

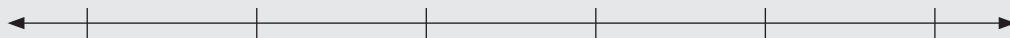
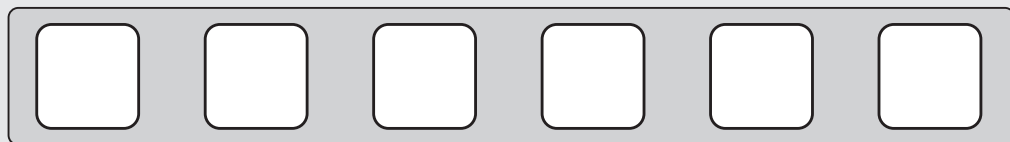

## Term I Lesson 33

## Themo ya I Ngudo ya 33

Review of numbers 0 to 10

U sedzulusa nomboro 0 u swika kha 10

## CLASSWORK MUSHUMO WA KILASINI

1 Fill in the missing number in the blank box.

Nwalani nomboro dzi no khou t̄ahela afho tshibogisini tshi si na tshithu.

1

6	
2	

2

0	9

3

6	4

4

4	
	3

5

7	
2	

6

9	1

7

3	
	3

8

3	2

9

6	3

10

10	
	2



2 Write the answer in the block.

Nwalani phindulo tshibu lokoni.

	Which is less? Ndi ifhio i re thukhu?	Answer Phindulo		Which is more? Ndi ifhio i re khulwane?	Answer Phindulo
1	1 or kana 2?		6	10 or kana 3?	
2	4 or kana 7?		7	6 or kana 2?	
3	8 or kana 3?		8	5 or kana 9?	
4	6 or kana 0?		9	4 or kana 1?	
5	2 or kana 3?		10	9 or kana 8?	

3 Write these numbers in order from the smallest to the biggest.

Nwalani nomboro dzi tshi tevhekana u bva kha tshukhusesa u swika kha khulwanesesa.

		Answer Phindulo
1	6, 9, 4, 10, 2, 5	
2	10, 7, 3, 0, 9, 8, 5	
3	5, 9, 2, 0, 3, 7, 6	
4	10, 7, 5, 2, 9, 6	
5	5, 2, 7, 3, 9, 0	
6	10, 6, 2, 0, 7, 3	
7	8, 5, 1, 3, 7, 2	
8	9, 0, 4, 8, 7	
9	6, 0, 9, 3, 4, 7	
10	1, 9, 3, 7, 5	

EXTENSION NYINGANYITO

Do the blocks have the same/different number of pictures?

Zwibulo zwi na tshivhalo tshi no fana/tsho fhambana tsha zwifanyiso?

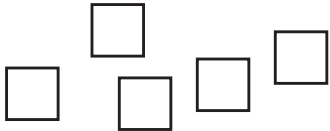
		<p>same tshi a fana</p>
		<p>different tsho fhambana</p>

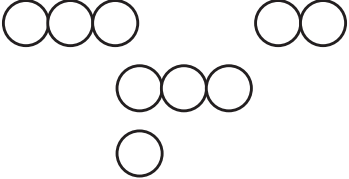
		<p>same tshi a fana</p>
		<p>different tsho fhambana</p>

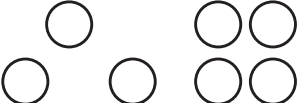
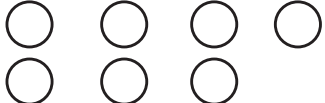
		<p>same tshi a fana</p>
		<p>different tsho fhambana</p>

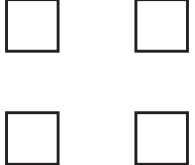
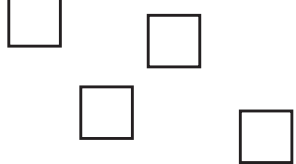
		<p>same tshi a fana</p>
		<p>different tsho fhambana</p>

# Term I Lesson 34

## Themo ya I Ngudo ya 34

Assessment

Ulinga

## Term I Lesson 35

## Themo ya I Ngudo ya 35

## Consolidation

## U ṭanganya magudiswa

- 1 Write the numbers in order from smallest to biggest.

Ñwalani nomboro dzi tshi tevhekano u bva kha ṭhukhusesa u ya kha khulwanesesa.

7, 3, 6	_____ , _____ , _____
5, 2, 8	_____ , _____ , _____
9, 7, 10	_____ , _____ , _____

- 2 Fill in the missing numbers.

Ñwalani nomboro dzi no khou ṭahela.

1

10	
4	

2

9	
	2

	7	
3	3	

	10	
4		0

	10	
5	5	

	10	
6		3

- 3 Find and circle all the number pairs that make 10. (vertically, horizontally and diagonally)

Wanani ni tingedzele phere dzothe dza nomboro dzi no vhumba 10. (Dzi tshi tsa, dzi tshi rambalala, na mubuḡakhuḡa/daegonaḡa)

6	1	2	8	9
3	4	3	6	4
5	2	7	1	5
4	5	2	9	8
8	2	3	7	3

- 4 Circle the number that is 3 less than 10.

Tangedzelani nomboro i re ṡhukhu kha 10 nga 3.

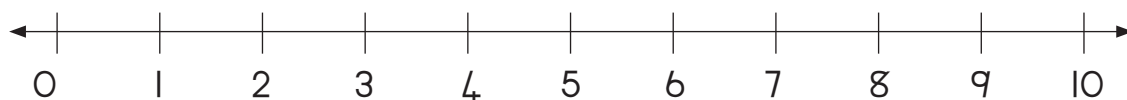

- 5 Circle the number that is 4 less than 9.

Tangedzelani nomboro i re ṭhukhu kha 9 nga 4.



- 6 Circle the number that is 2 more than 3.

Tangedzelani nomboro i re khulwane kha 3 nga 2.



- 7 Circle the number that is 1 less than 1.

Tangedzelani nomboro i re ṭhukhu kha 1 nga 1.



# Term I Lesson 36

## Themo ya I Ngudo ya 36

Ordinal numbers

Nomboro thevhekani

### CLASSWORK MUSHUMO WA KILASINI

1 Squares for classwork activity 3.

Zwikwea zwa nyito ya mushumo wa kilasini ya 3.

--	--	--	--	--	--	--	--	--	--

2 Answer the following. Circle the correct answer.

Fhindulani zwi tevhelaho. Tangedzelani phindulo yone.

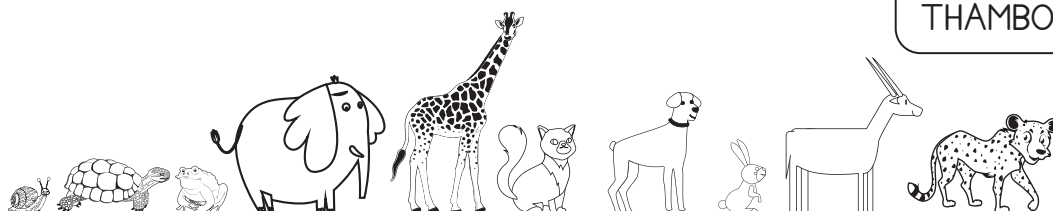

FINISH  
THAMBONI

a	Who came first? Ndi nnyi a re kha vhuimo ha u thoma?	Buck Tsepe	cheetah ḡagaladzhie
b	Who came last? Ndi nnyi a re kha vhuimo ha u fhedza?	snail khumba	tortoise tshibode
c	Who came third? Ndi nnyi a re kha vhuimo ha vhuraru?	Buck Tsepe	rabbit muvhūḡa
d	Who came seventh? Ndi nnyi a re kha vhuimo ha vhusumbe?	elephant ḡḡou	cat tshimange
e	Who came second? Ndi nnyi a re kha vhuimo ha vhuvhili?	Giraffe Ḥuḡa	buck tsepe
f	Who came eighth? Ndi nnyi a re kha vhuimo ha vhumalo?	frog tshidula	cat tshimange



<b>g</b>	Who came fourth? Ndi nnyi a re kha vhuimo ha vhuᵛa?	elephant ndou	dog mmbwa
<b>h</b>	Who came ninth? Ndi nnyi a re kha vhuimo ha vhuᵛahe?	tortoise tshibode	snail khumba
<b>i</b>	Who came fifth? Ndi nnyi a re kha vhuimo ha vhuᵛanu?	cheetah ᵛagaladzhie	cat tshimange
<b>j</b>	Who came sixth? Ndi nnyi a re kha vhuimo ha vhurathi?	giraffe ᵛhuda	dog mmbwa

3 Colour the correct circle:

Khaᵛarani tshitendeledzi tshone:

- a** The 3<sup>rd</sup> circle from the right.  
Tshitendeledzi tsha vhuraru (vhu3) u bva kha tsha u ᵛa.
- b** The 5<sup>th</sup> circle from the left.  
Tshitendeledzi tsha vhuᵛanu (vhu5) u bva kha tsha monde.
- c** The 1<sup>st</sup> circle from the bottom  
Tshitendeledzi tsha u thoma (vhu1) u bva fhasi.
- d** The 2<sup>nd</sup> circle from the top.  
Tshitendeledzi tsha vhuvhili (vhu2) u bva nᵛha.

<b>a</b>	<b>b</b>	<b>c</b>	<b>d</b>
○ ○ ○ ○ ○	○ ○ ○ ○ ○	○ ○ ○ ○ ○	○ ○ ○ ○ ○

### EXTENSION NYINGANYITO

1 Draw ten triangles in your classwork book:

Olani thiraiengele dza fumi kha bugu yanu ya mishumo ya klasini:

a Draw a dot in the second triangle from the left.

Olani tshithoma kha thiraiengele ya vhuvhili u bva kha tsha monde.

b Draw a star in the eighth triangle from the left.

Olani naledzi kha tharaiengele ya vhumalo u bva kha tsha monde.

c Cross out the fifth triangle from the left.

Hwayani thiraiengele ya vhuṭanu u bva kha tsha monde.

d Colour in the ninth triangle from the left.

Khalarani thiraiengele ya vhuṭahe u bva kha tsha monde.

e Put a tick (✓) in the sixth triangle from the left.

Dzhenisani thiki (✓) kha thiraiengele ya vhurathi u bva kha tsha monde.

# Term I Lesson 37

## Themo ya I Ngudo ya 37

Ordinal and cardinal numbers

Nomboro thevhekani na nomboro ya khadinala

### CLASSWORK MUSHUMO WA KILASINI

1 Draw 10 circles in your classwork book. Then:

Olani zwitendeledzi zwa 10 buguni yaṅu ya mishumo ya kilasini. Ni kone u:

a Cross out the ninth circle from the right.

Hwaya tshitendeledzi tsha vhuṭahe u bva kha tsha u 1a.

b Draw a face in the third circle from the right.

Olani tshifhatuwo nga ngomu ha tshitendeledzi tsha vhuraru u bva kha tsha u 1a.

c Draw a triangle in the last circle from the right.

Olani thiraiengele nga ngomu ha tshitendeledzi tsha u fhedza u bva kha tsha u 1a.

d Colour in the first circle from the right.

Khaḷarani tshitendeledzi tsha u thoma u bva kha tsha u 1a.

e Draw a heart in the fourth circle from the right.

Olani mbilu nga ngomu ha tshitendeledzi tsha vhuṅa u bva kha tsha u 1a.

f Draw a square in the seventh circle from the right.

Olani tshikwea nga ngomu ha tshitendeledzi tsha vhusumbe u bva kha tsha u 1a.

2 Colour the correct circle or circles:

Khaḷarani tshitendeledzi tshone kana zwitendeledzi zwone.

a The third circle from the right.

Tshitendeledzi tsha vhuraru u bva kha tsha u 1a.



b Three circles from the right.

Zwitendeledzi zwiraru u bva kha tsha u 1a.



- c The fifth circle from the left.  
Tshitenededzi tsha vhuṭanu u bva kha tsha monde. ○○○○○○○○○○○
- d Five circles from the left.  
Zwitenededzi zwiṭanu u bva kha tsha monde. ○○○○○○○○○○○
- e The eighth circle from the right.  
Tshitenededzi tsha vhumalo u bva kha tsha u la. ○○○○○○○○○○○
- f Eight circles from the right.  
Zwitenededzi zwa malo u bva kha tsha u la. ○○○○○○○○○○○
- g The sixth circle from the left.  
Tshitenededzi tsha vhurathi u bva kha tsha monde. ○○○○○○○○○○○
- h Six circles from the left.  
Zwitenededzi zwa rathi u bva kha tsha monde. ○○○○○○○○○○○
- i Four circles from the bottom.  
Zwitenededzi zwiṇa u bva fhasi.
- j The fourth circle from the bottom.  
Tshitenededzi tsha vhuṇa u bva fhasi.
- k Two circles from the top.  
Zwitenededzi zwivhili u bva nṭha.
- l The second circle from the top.  
Tshitenededzi tsha vhuvhili u bva nṭha.

i	j	k	l
---	---	---	---

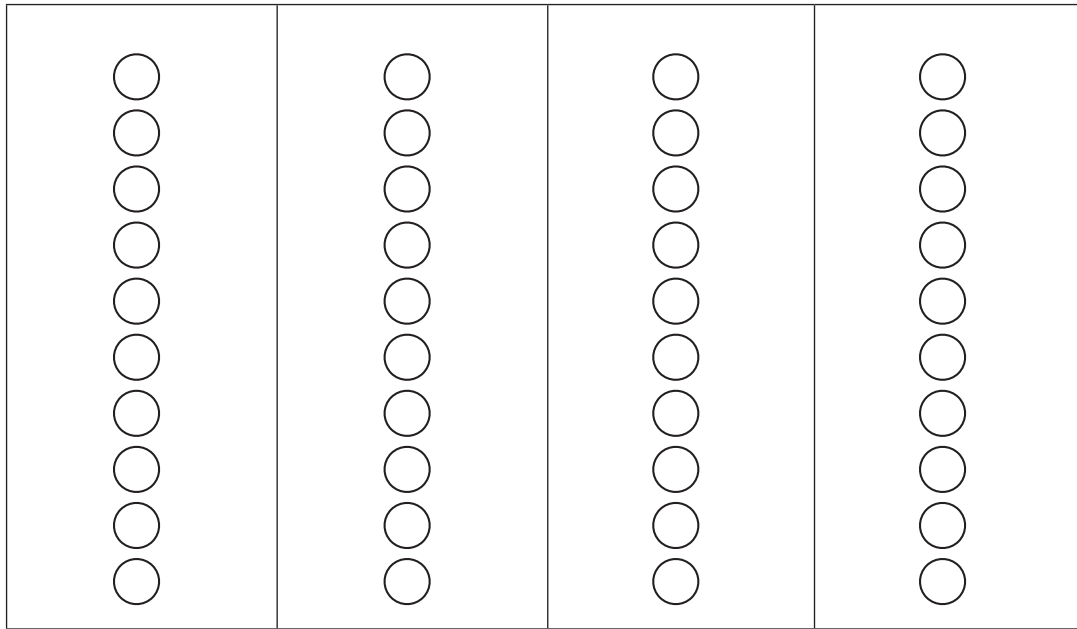







## EXTENSION NYINGANYITO

1 Colour the correct circle or circles:

Khaxarani tshitendeledzi tshone kana zwitendeledzi zwone:

- a Three circles from the bottom.  
Zwitendeledzi zwiraru u bva fhasi.
- b The sixth circle from the bottom.  
Tshitendeledzi tsha vhurathi u bva fhasi.
- c Five circles from the top.  
Zwitendeledzi zwiṭṭanu u bva nṭha.
- d The eighth circle from the top.  
Tshitendeledzi tsha vhumalo u bva nṭha.

a	b	c	d
			

# Term I Lesson 38

## Themo ya I Ngudo ya 38

Assessment

Ulinga



# Term 1 Lesson 39

## Themo ya 1 Ngudo ya 39

3-D objects – Constructing figures

Zwithu zwa 3-D - U fhaṭa zwivhumbiwa

### CLASSWORK MUSHUMO WA KILASINI

- 1 There is no written classwork for today.  
Namusi a huna mushumo wa kilasini wa u tou n̄wala.
- 2 Use this time for learners to present their figures to the class.  
Kha vha shumise hetshi tshifhinga kha uri vhagudi vha kumedzele kilasi zwivhumbiwa zwavho.
- 3 It is important for learners to identify the 3-D objects used in the construction of their figure.  
Zwi na ndeme uri vhagudi vha topole zwithu zwa 3-D zwe vha zwi shumisa kha zwivhumbiwa zwavho.

### EXTENSION NYINGANYITO

- 1 Collect 4 items from inside or outside your home.  
Kuvhanganyani zwithu zwa 4 ngomu nduni ya haṅu kana nṅḁa.
- 2 Plan the construction of your figure by drawing.  
Olani pulane ya u fhaṭa tshivhumbiwa tshaṅu.
- 3 Construct your figure. (No glue / stapler / sticky tape may be used).  
Fhaṭani tshivhumbiwa tshaṅu (A hu shumiswi guḽuu/ tshiṭepuḽara/ theiphi ya u nambatedza).

# Term I Lesson 40

## Themo ya I Ngudo ya 40

### Consolidation

### U ṭanganya magudiswa

- 1 Draw the shapes on the line by following the instructions:  
Olani zwiwumbeo kha vhutalo ni tshi tevhedza ndaela:

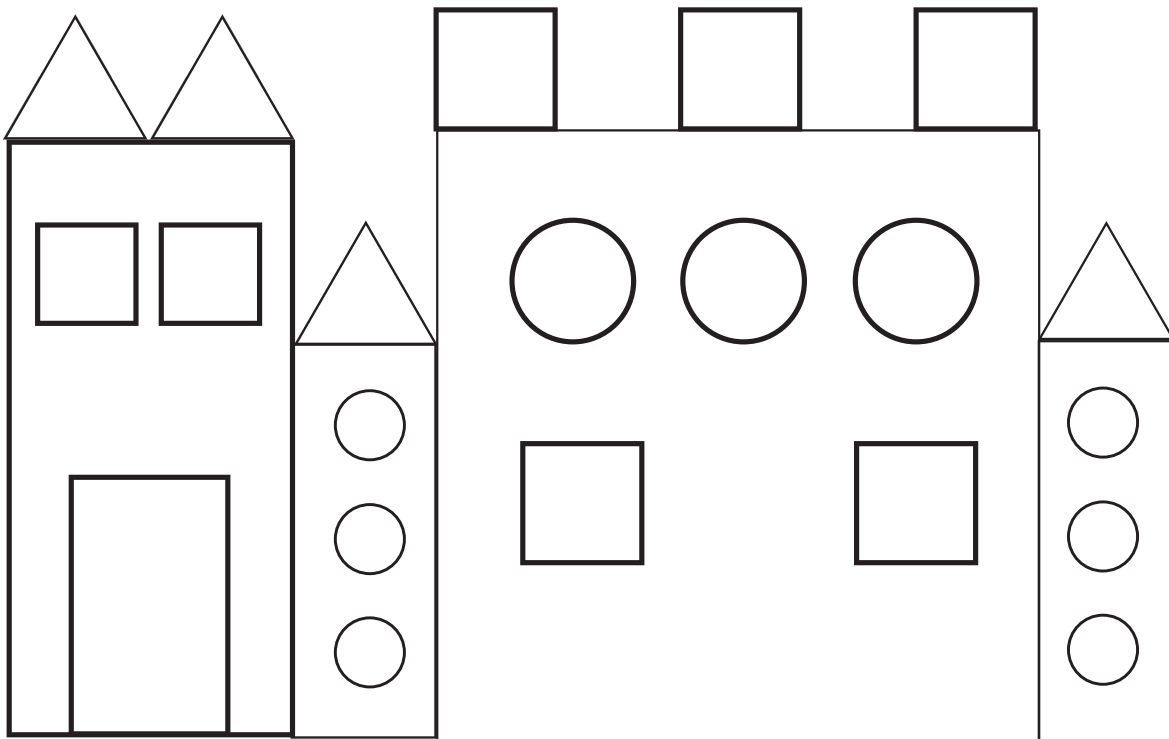

- Draw a star under the fifth line from the left.  
Olani n̄aledzi fhasi ha kutalo kwa vhuṭanu u bva kha tsha monde.
- Draw a circle under the third line from the right.  
Olani tshitendeledzi fhasi ha kutalo kwa vhuraru u bva kha tsha u ḽa.
- Put a heart under the line seventh from the left.  
Olani mbilu fhasi ha kutalo kwa vhusumbe u bva kha tsha monde.
- Put a triangle under the first four lines from the left.

Olani thiraiengele fhasi ha kutalo kwa vhuṅa u bva kha tsha monde.

- e Put a square under the first two lines from the right.

Olani tshikwea fhasi ha vhutalo vhuvhili ha u thoma u bva kha tsha u ḽa.

- f Put a cross under the line sixth from the left.





Olani tshifhambano fhasi ha kutalo kwa vhurathi u bva kha tsha monde.

- g Put a smiley face under the line fourth from the right.

Olani tshifhaṭuwotshinwethuwi fhasi ha kutalo kwa vhuṭahe u bva kha tsha u ḽa.

2 Answer the questions about the children below.

Fhindulani mbudziso dzi no kwama vhana vha re afho fhasi.

<div style="display: flex; justify-content: space-around; align-items: center;"> <div style="border: 1px solid black; padding: 2px 10px; margin: 2px;">Sipho</div> <div style="border: 1px solid black; padding: 2px 10px; margin: 2px;">Lerato</div> <div style="border: 1px solid black; padding: 2px 10px; margin: 2px;">John</div> <div style="border: 1px solid black; padding: 2px 10px; margin: 2px;">Peter</div> <div style="border: 1px solid black; padding: 2px 10px; margin: 2px;">Anne</div> </div> <div style="display: flex; justify-content: space-around; align-items: center; margin-top: 10px;">      </div>	
<p>1 Who is third from the left? Ndi nnyi a re wa vhuraru u bva kha tsha monde?</p>	
<p>2 Who is second from the right? Ndi nnyi a re wa vhuvhili u bva kha tsha u la?</p>	
<p>3 Who is fourth from the right? Ndi nnyi a re wa vhuṅa u bva kha tsha u la?</p>	
<p>4 Who is first from the left? Ndi nnyi a re wa u thoma u bva kha tsha monde?</p>	
<p>5 Who are the first three learners from the left? Ndi vhagudi vhafhio vhararu vha u thoma ri tshi bva kha tsha monde?</p>	
<p>6 Who are the first two learners from the right? Ndi vhagudi vhafhio vhavhili vha u thoma ri tshi bva kha tsha u la?</p>	

## Term 1 Lesson 41

## Themo ya 1 Ngudo ya 41

Properties of solids



Mbonalo ya zwiomate

## CLASSWORK MUSHUMO WA KILASINI

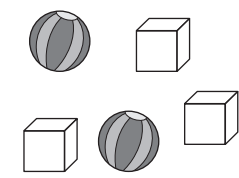
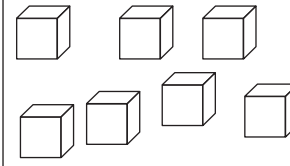
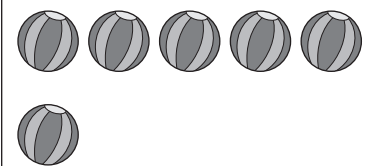
- Which of these pictures look like balls? Mark the circle.  
Ndi zwifanyiso zwifhio kha izwi zwi no nga bola? Swayani tshitendeledzi.
- Which of these pictures look like boxes? Mark the square.  
Ndi zwifanyiso zwifhio kha izwi zwi no nga mabogisi? Swayani tshikwea.
- Can you build a tower with all of the following objects? Write yes or no.  
Ni nga kona u fhaṭa thawara nga izwi zwithu zwoṭhe? Nwalani ee kana hai.

a		b		c	

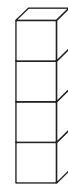
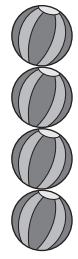
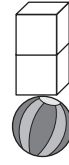
- Will the tower stand? Write yes or no.  
Thawara ya hone i ḡo ima? Nwalani ee kana hai.

a		b		c		d	

- Use ten matchboxes and glue to make your own building.

Shumisani bogisi la metshisi na guḽuu kha u fhaḽa tshifhaḽo tsha inwi muḽe.

EXTENSION NYINGANYITO

- 1 Collect boxes and balls at home.  
Kuvhanganyani zwibogisi na bola hayani.
- 2 Build your own tower (or other shape).  
Fhaḽani thawara ya inwi muḽe (kana tshivhumbeo tshinwevho)
- 3 What shape did you build?  
No fhaḽa tshivhumbeoḽe
- 4 Bring it to school to show your teacher.  
Iḽani natsho tshikoloni ni sumbedze mudededzi waḽu..

# Term I Lesson 42

## Themo ya I Ngudo ya 42

Balls and boxes

Bola na mabogisi

CLASSWORK MUSHUMO WA KIḽASINI

- 1 Draw the objects in the correct block.  
Olani zwithu tshibuḽokoni tshone.

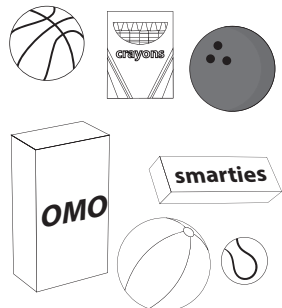
	<p>Balls Bola</p>	<p>Boxes Zwibogisi</p>
---	-------------------	------------------------





2 Draw the objects into the correct block.

Olani zwithu tshibu lokoni tshone.

	Small balls Bola ṭhukhu	Small boxes Zwibogisi zwiṭuku
	Big balls Bola khulwane	Big boxes Zwibogisi zwiḥulwane

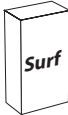
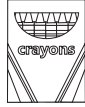
3 Will these objects roll or slide? Write the correct answer.

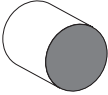
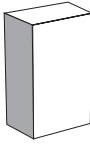
Izwi zwithu zwi ḡo kunguluwa kana u swenda. Nwalani phindulo yone.

- a  \_\_\_\_\_
- b  \_\_\_\_\_
- c  \_\_\_\_\_
- d  \_\_\_\_\_
- e  \_\_\_\_\_
- f  \_\_\_\_\_
- g  \_\_\_\_\_

### EXTENSION NYINGANYITO

- 1 Find four objects at home. Make a slope by placing a box under one end of a big book.

Wanani zwithu zwiṅa hayani. Itani muṭuluwo nga u vhea bogisi nga fhasi ha mugumo muthihi wa bugu.

- 2 Test each object to see whether it can roll or slide.

Lingani tshithu nga tshithihi nga tshithihi ni vhone arali tshi tshi ḡo kunguluwa kana tsha swenda.

- 3 Draw the objects that can roll on the left side of your page and the objects that can slide on the right side of your page.

Olani zwithu zwine zwa nga kunguluwa kha tshanda tsha monde tsha siaṭari na zwine zwa nga swenda kha tshanda tsha u ḷa tsha siaṭari.

- 4 Label your group of pictures: roll/slide.

Ḳebuḷani/Nwalani kha zwifanyiso zwanu uri: kunguluwa/swenda.



# Term I Lesson 43

## Themo ya I Ngudo ya 43

2-D shapes

Zwivhumbeo zwa 2-D

CLASSWORK MUSHUMO WA KILASINI

Look at the picture and answer the questions.

Lavhelesani tshifanyiso ni fhindule mbudziso.

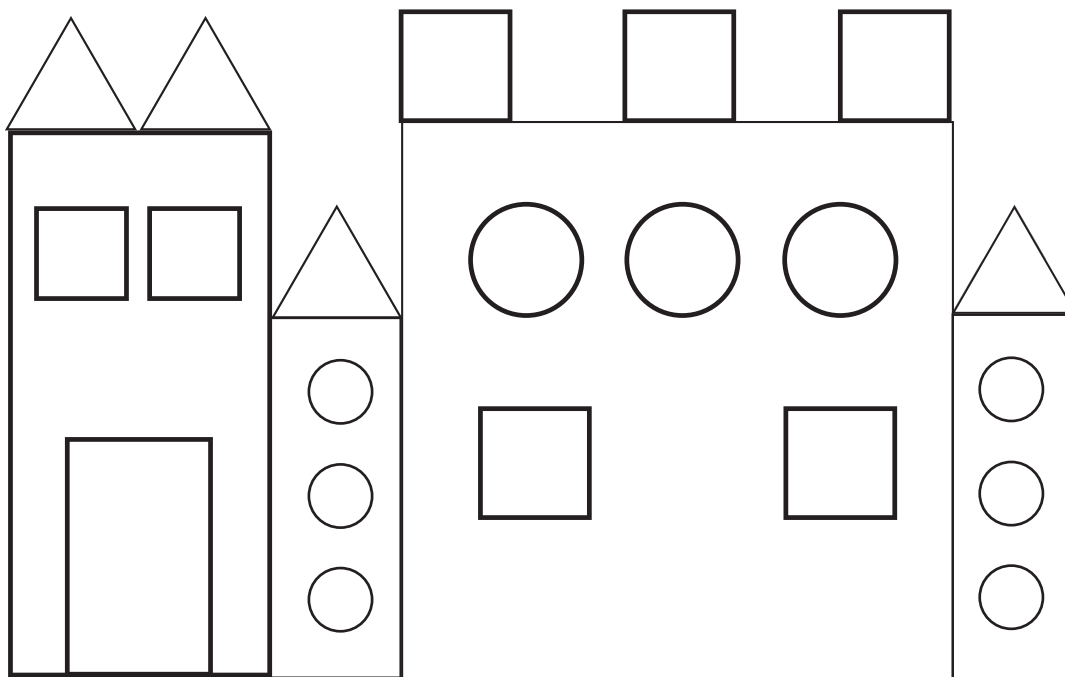

- 1 How many squares are there?  
Hu na zwickwea zwingana? \_\_\_\_\_
  
- 2 How many triangles are there?  
Hu na thiraiengele nngana? \_\_\_\_\_
  
- 3 How many circles are there?  
Hu na zwitendeledzi zwingana? \_\_\_\_\_
  
- 4 What other shapes can you see?  
Ndi zwivhumbeo zwiwwe zwifhio zwine na kona u zwi vhona? \_\_\_\_\_
  
- 5 Colour in the picture.  
Kha\arani tshifanyiso.

## EXTENSION NYINGANYITO

1 Answer the questions in the table.

Fhindulani mbudzo dzi re kha thebuḽu.

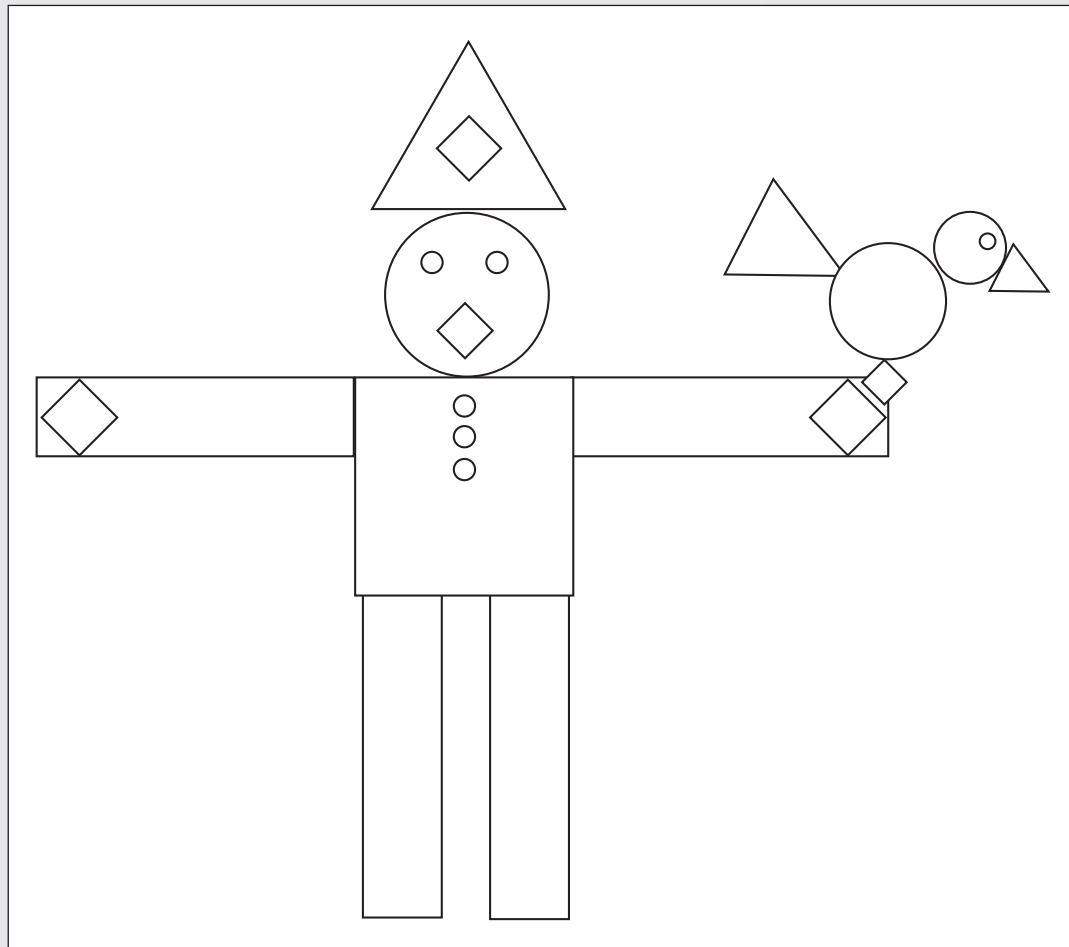

**a** How many squares can you find?  
Ndi zwickwea zwingana zwe na wana?

**b** How many circles can you find?  
Ndi zwitendeledzi zwingana zwe na wana?

**c** How many triangles can you find?  
Ndi thiraiengele nngana dze na wana?

**d** How many rectangles can you find?  
Ndi rekhithiengele nngana dze na wana?

Term I Lesson 44

Themo ya I Ngudo ya 44

Assessment

Ulinga

## Term 1 Lesson 45

## Themo ya 1 Ngudo ya 45

## Consolidation

## U ṭanganya magudiswa

- Find two ball and two box pictures and paste them in your maths book.  
Wanani zwifanyiso zwivhilizwivhili zwa bola na zwa mabogisi ni zwi nambatedze buguni yanu ya mbalo.
- Draw a triangle around the objects that can slide and a heart around the objects that can roll.  
Olani thiraiengele nthihi u mona na zwithu zwine zwa swenda na mbilu u mona na zwithu zwine zwa kunguluwa.



- Write the sentences using the correct word.  
Nwalani mafhungo ni tshi shumisa ipfi lone..

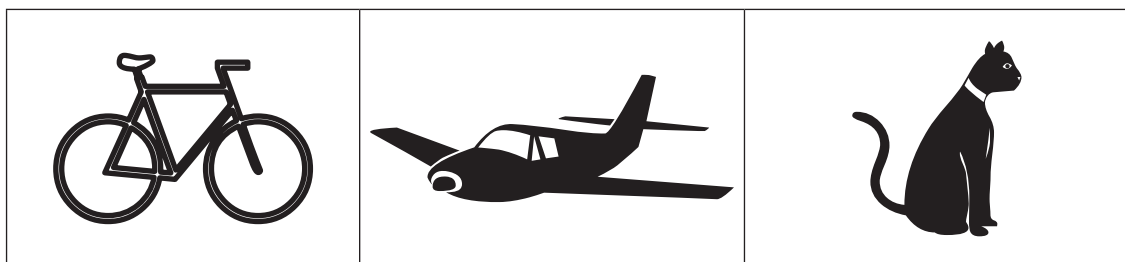

- A bicycle is bigger/smaller than an aeroplane.  
Baisigiri ndi khulwane/ṭhukhu kha bufho.

- b A cat is bigger/smaller than a bicycle.  
Tshimange ndi tshihulwane/tshitukhu kha baisigiri
- c An aeroplane is bigger/smaller than a cat.  
Bufho ndi lihulwane/liitukhu kha tshimange
- 4 Draw a big ball and a bigger ball.  
Olani bola khulwane na bola khulwanesa.
- 5 Draw a big box and a bigger box.  
Olani bogisi lihulwane na bogisi lihulwanesa.
- 6 Draw a small box and a smaller box.  
Olani bogisi litukhu na bugisi litukusa.
- 7 Draw a small ball and a smaller ball.  
Olani bola tshukhu na bola tshukusa.
- 8 Is the smaller ball on the left or on the right?  
Bola tshukusa i kha tsha monde kana kha tsha u la?

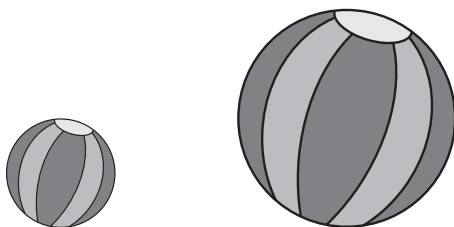

# Term 1 Lesson 46

## Themo ya I Ngudo ya 46

Faces of 3-D objects

Vhurumbu ha zwithu zwa 3-D

### CLASSWORK MUSHUMO WA KILASINI

- 1 Cut out all your shapes.  
Gerani zwivhumbeo zwanu zwothe.
- 2 Put all your shapes in groups of similar shapes.  
Vheani zwivhumbeo zwanu kha zwigwada zwa zwivhumbeo zwi no fana.
- 3 Use your shapes to create a picture.  
Shumisani zwivhumbeo zwanu kha u sika tshifanyiso.
- 4 Copy your picture into your classwork book.  
Kopolelani tshifanyiso tshanu kha bugu yanu ya mishumo ya kilasini.

### EXTENSION NYINGANYITO

- 1 Trace 5 different faces from objects that you found at home.  
Tevhedzelani vhurumbu ha 5 ho fhambanaho ha zwithu zwe na zwi wana hayani.
- 2 Write the name of the object below the face that you traced.  
Nwalani dzina la tshivhumbeo nga fhasi ha lurumbu lwe na tevhedzela.

# Term I Lesson 4.7

## Themo ya I Ngudo ya 4.7

Geometric patterns

Phetheni dza dzhometiri

### CLASSWORK MUSHUMO WA KILASINI

- 1 Extend the patterns.  
Engedzani phetheni.

a	
b	
c	
d	

- 2 Fill in the missing spaces to complete the pattern.  
Dadzani mavhaka ni tshi fhedzisa phetheni.

--	--	--

- 3 Draw your own pattern.  
Olani phetheni ya inwi muṅe.



## EXTENSION NYINGANYITO

1 Extend the pattern.

Engedzani phetheni.

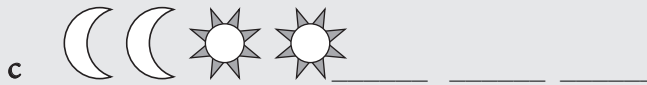

# Term I Lesson 48

## Themo ya I Ngudo ya 48









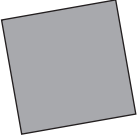
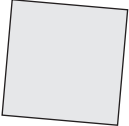
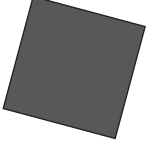

More geometric patterns

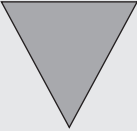
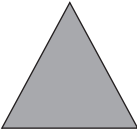
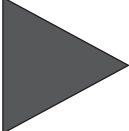
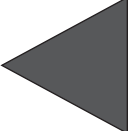
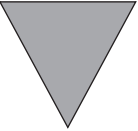
Phetheni dza dzhometiri dzinwe hafhu

### CLASSWORK MUSHUMO WA KILASINI

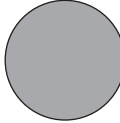
- I Circle the shape that is the same as the shape in the first box.

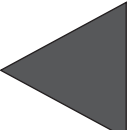
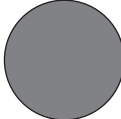
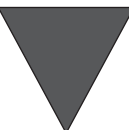
Tangedzelani tshivhumbeo tshi no fana na tshivhumbeo tshi re tshibogisini tsha u thoma.

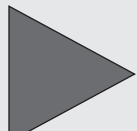
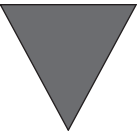
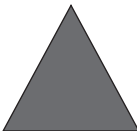
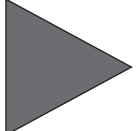
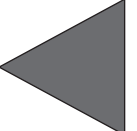
2 Extend the patterns.

Engedzani phetheni.

EXTENSION NYINGANYITO

Extend the patterns.

Engedzani phetheni.

Term I Lesson 49

Themo ya I Ngudo ya 49

Assessment

Ulinga

## Term I Lesson 50

## Themo ya I Ngudo ya 50

Consolidation

U ṭanganya magudiswa

- 1 Complete the patterns on the huts. Colour them in when you have finished.  
Fhedzisani phetheni dzi re kha n̄du. Dzi khạareni musi no no fhedza.

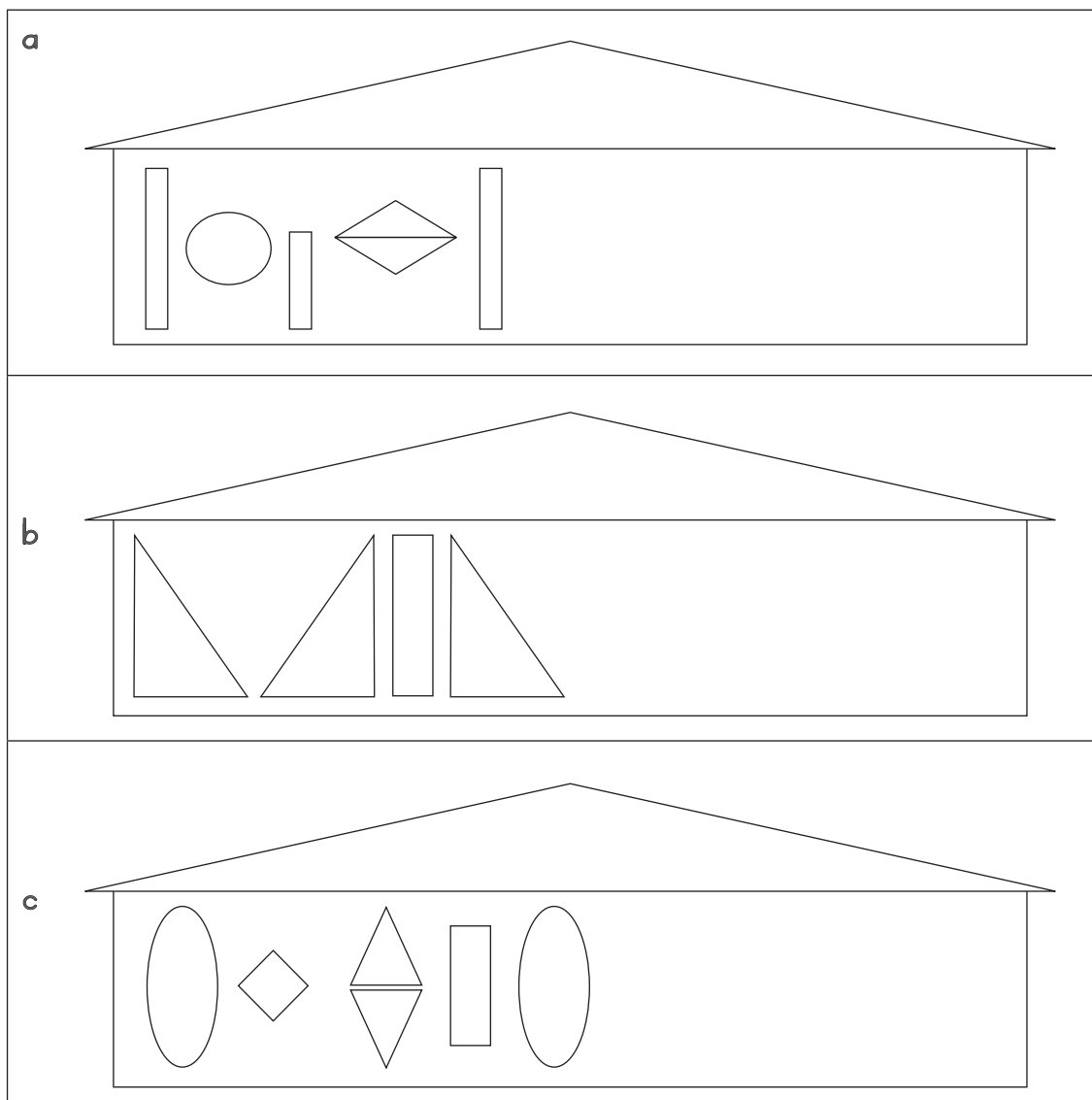





# Patterns worksheet (Week 1 baseline assessment topic 8)

Bammbiri la u shumela la phetheni (vhege ya I, thero ya 8 ya u linga ha muteo)

- 1 Extend the patterns by matching the shapes.  
Engedzani phetheni nga u livhanya zwivhumbeo.

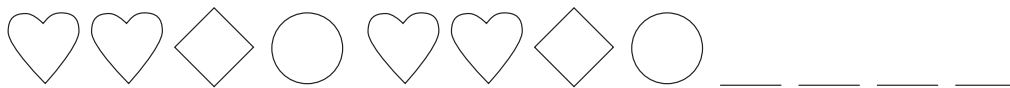

- 2 Follow the lines with your pencil.  
Tevhelani mitalo nga penisela..

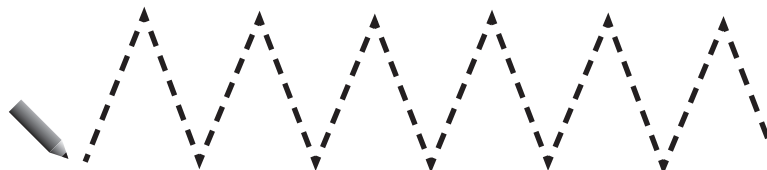





## Arrow cards (Lesson 2)

### Garaṭa dza misevhe (Ngudo ya 2)

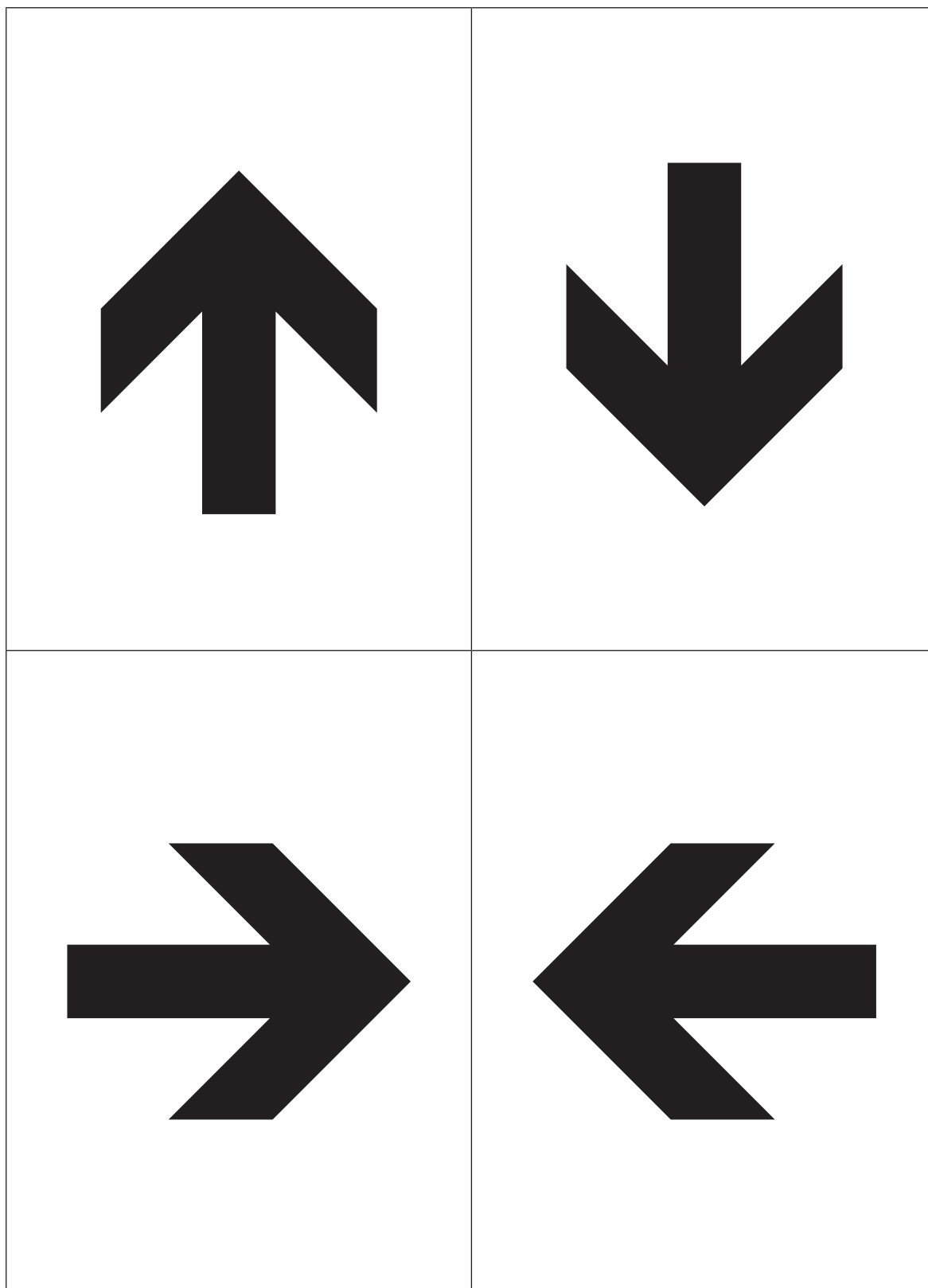

Tracing card (Lesson 2 and 3)

Garaṭa dza u tevhezela (Ngudo ya 2 na ya 3)

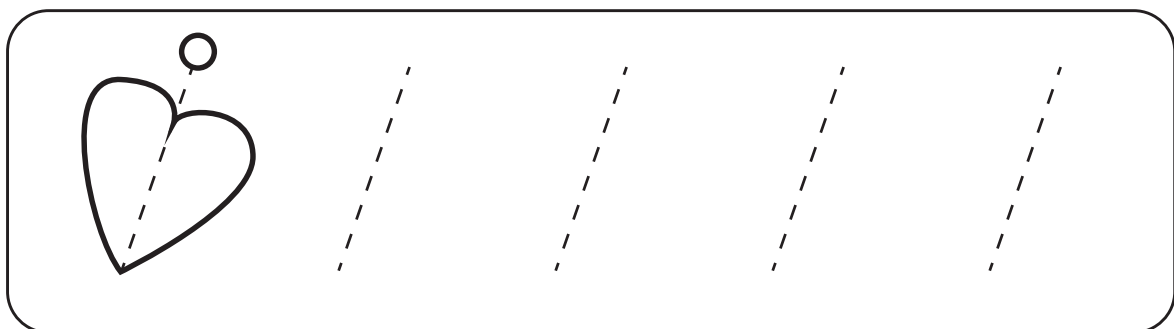
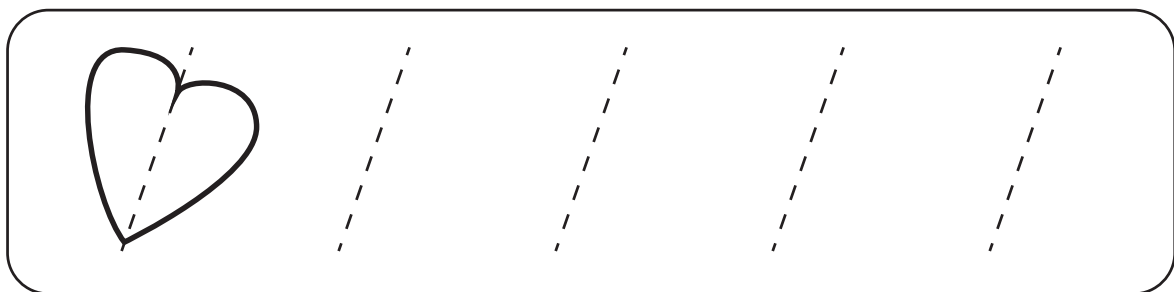
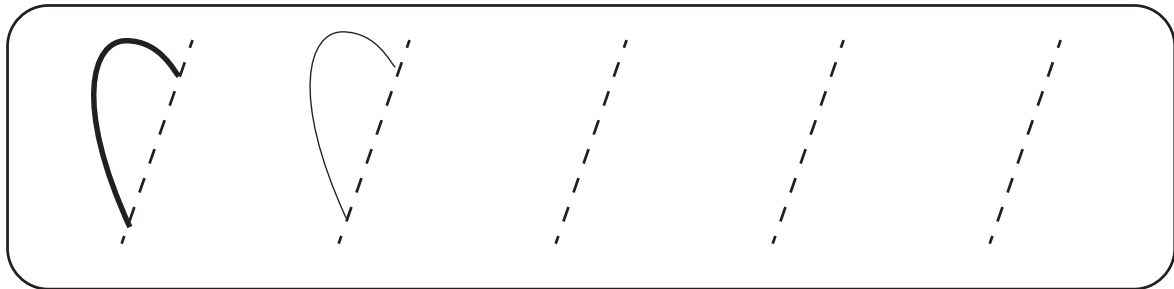
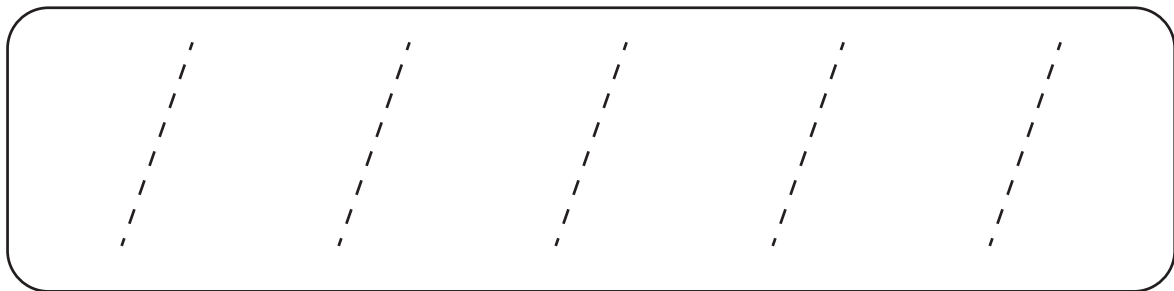

# Matching clothes (Lesson 4)

## Zwiambaro zwi no yelana (Ngudo ya 4)

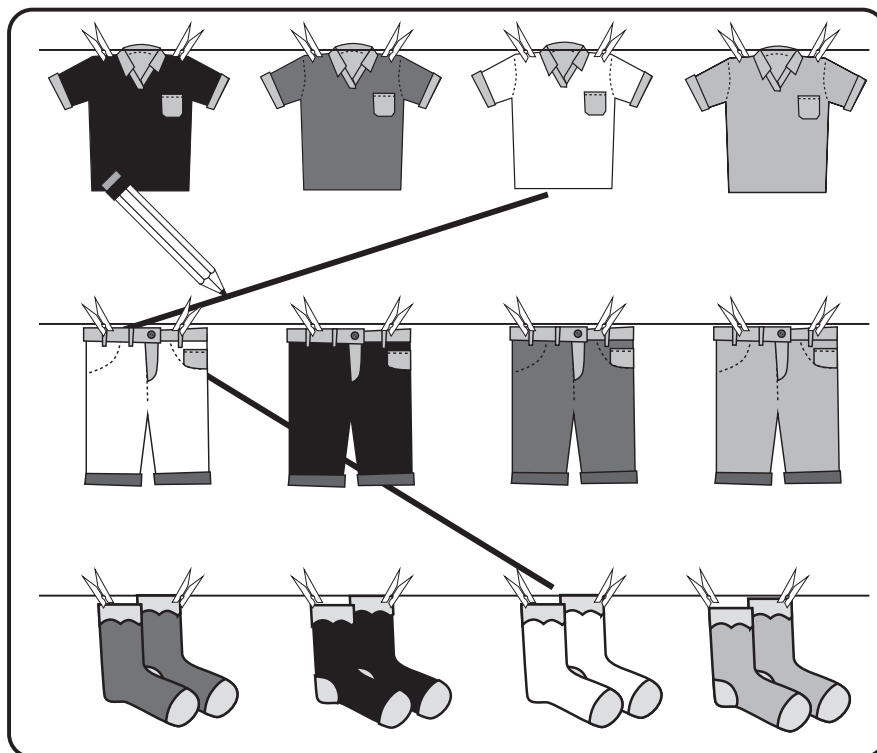
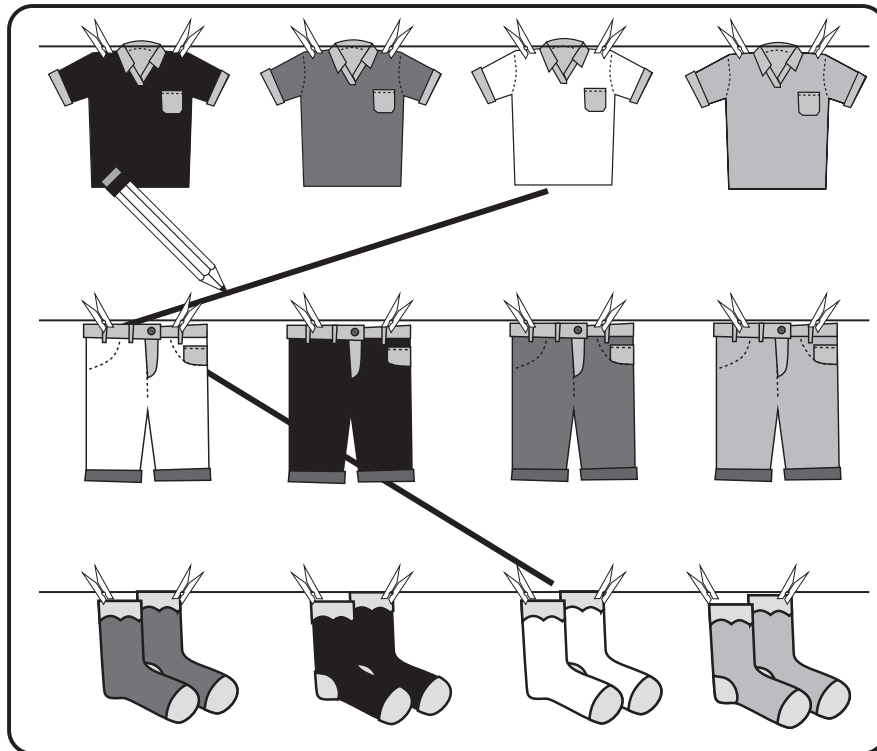

(a) Star cards (Lesson 4)

Garaṭa dza ṅaledzi (Ngudo ya 4)

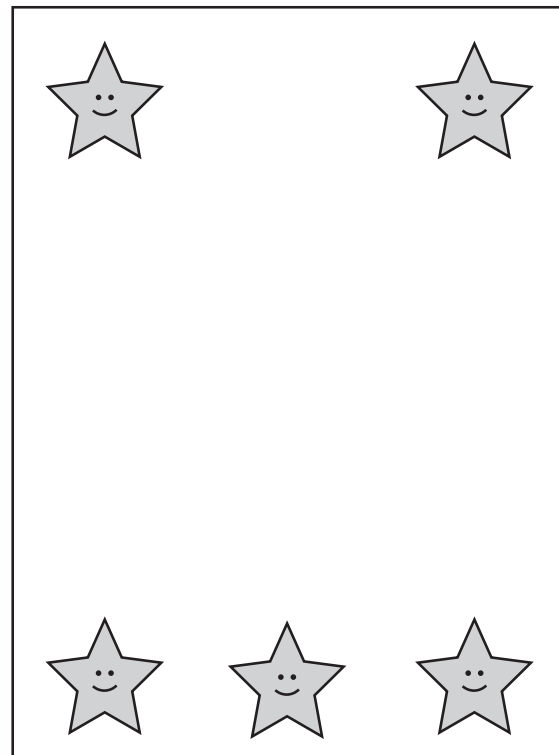
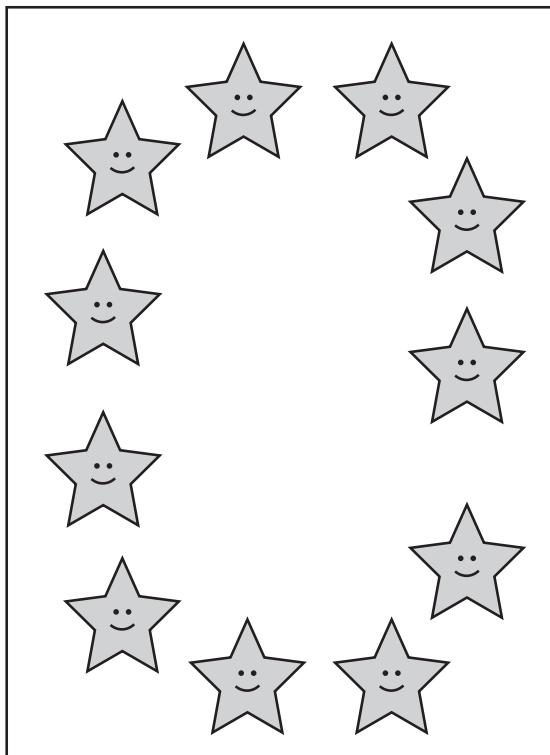
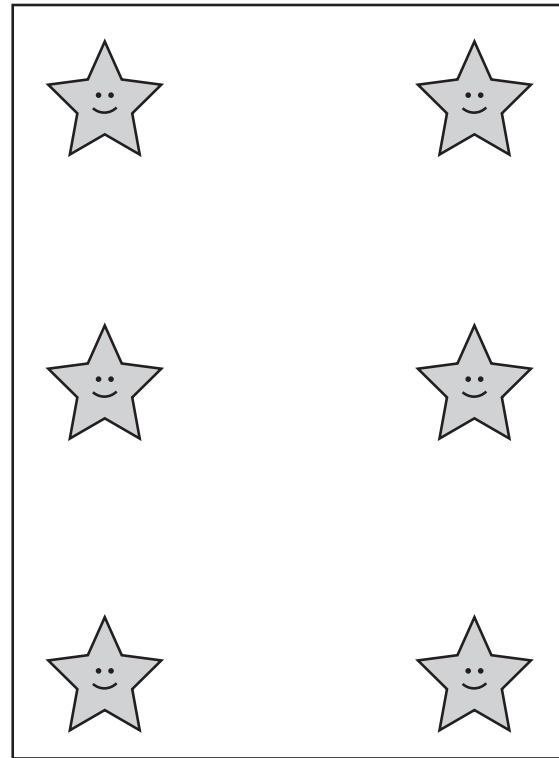
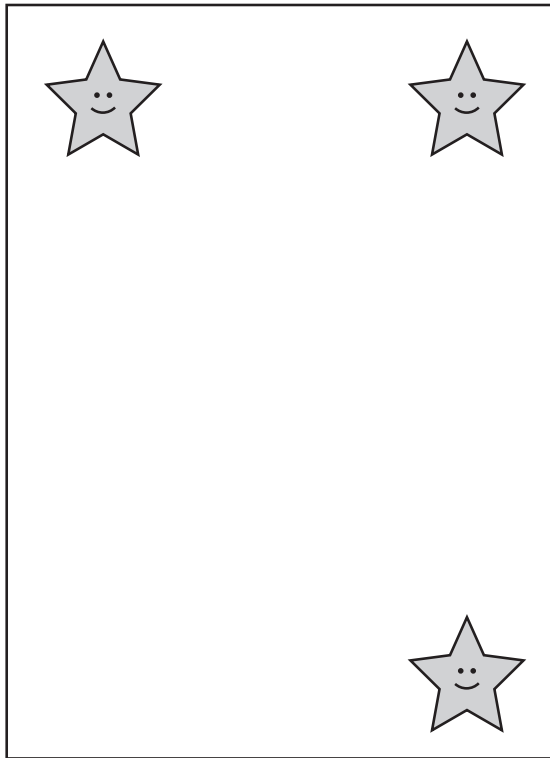



(b) Star cards (Lesson 4)

Garaṭa dza ṅaledzi (Ngudo ya 4)

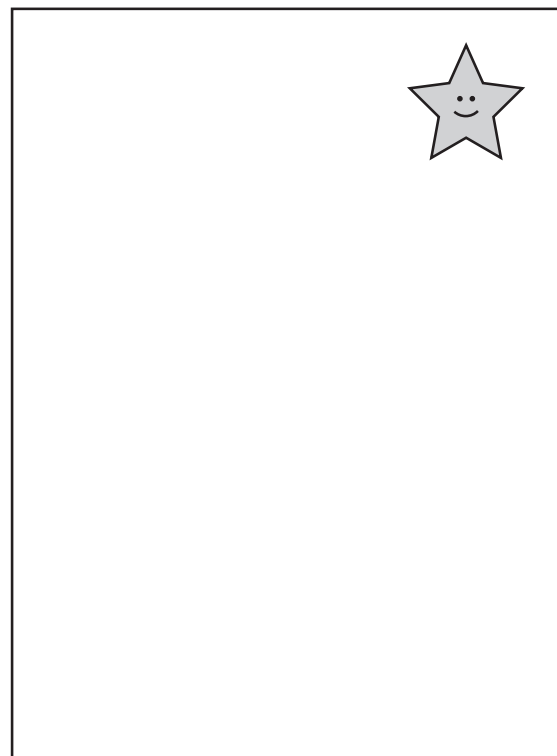
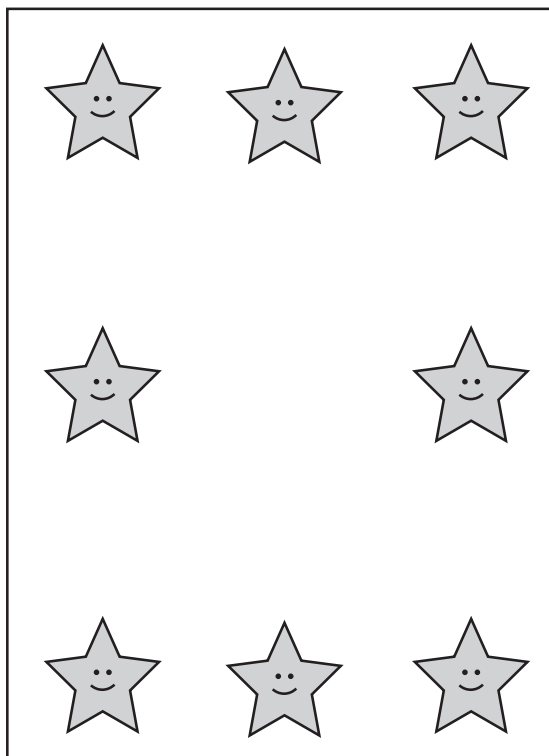
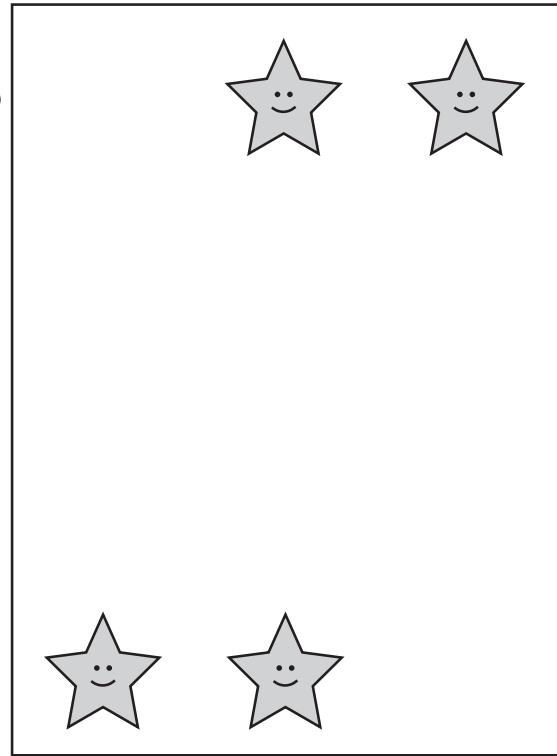
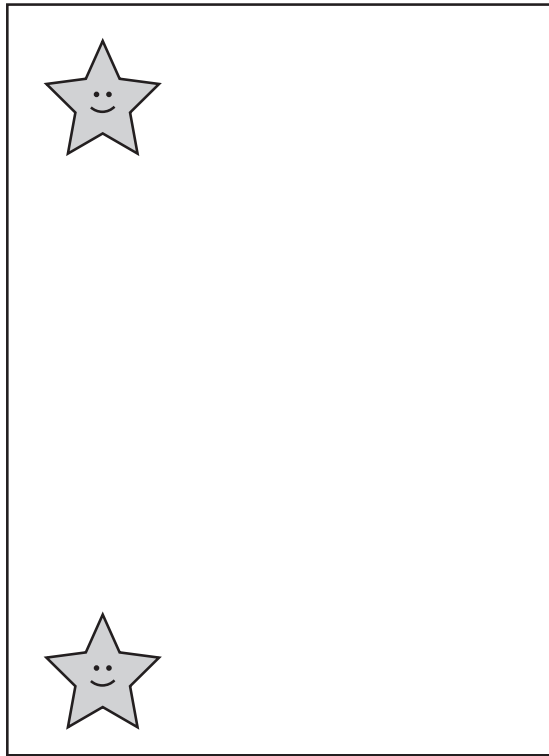





Farm scene (Lesson 6 and 8)

Nzulele ya bulasini (Ngudo ya 6 na 8)



### Number tracing cards (Lesson 9)

Garɗa dza u tevhedzela nomboro (Ngudo ya 9)



### Number tracing cards (Lesson II)

Carɔɔa dza u tevhedzela nomboro (Ngudo ya II)



3

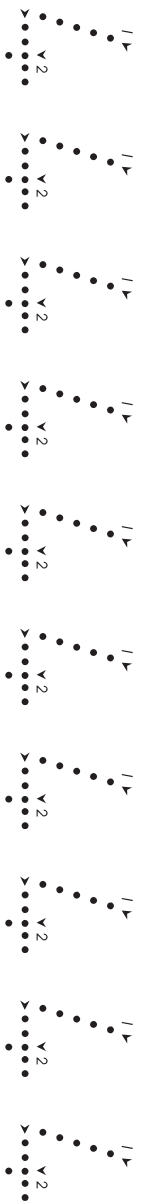

4

# Number tracing cards (Lessons 12 and 17)

Garata dza u tevhedzela nomboro (Ngudo ya 12 na ya 17)

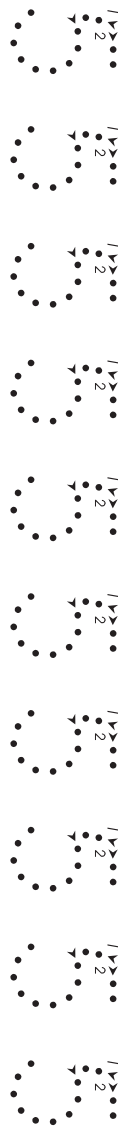

# 5



# 6

# Number tracing cards (Lessons 17 and 18)

Garata dza u tevhedzela nomboro (Ngudo ya 17 na ya 18)



Number tracing cards (Lessons 18 and 19)

Garata dza u tevhedzela nomboro (Nqudo ya 18 na ya 19)



9



10

# Number tracing cards (Lesson 29)

Carɔɔa dza u tevhedzela nomboro (Ngudo ya 29)

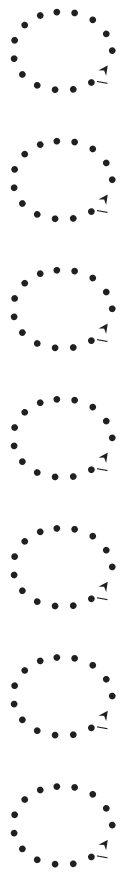

0



Zero

- (a) Number picture cards (ten frame cards)  
(Lesson 23 and others)

Garaṭa dza zwifanyiso zwa nomboro (garaṭa dza fureme ya mahumi) (Ngudo ya 23 na dziṅwe)

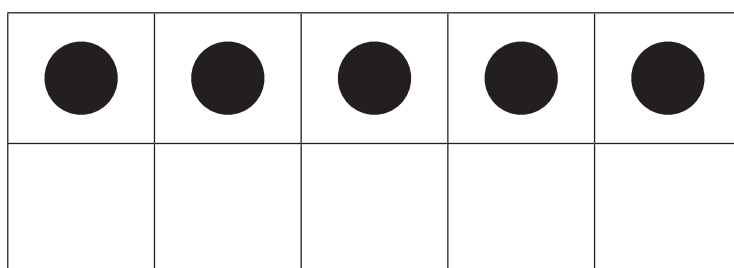
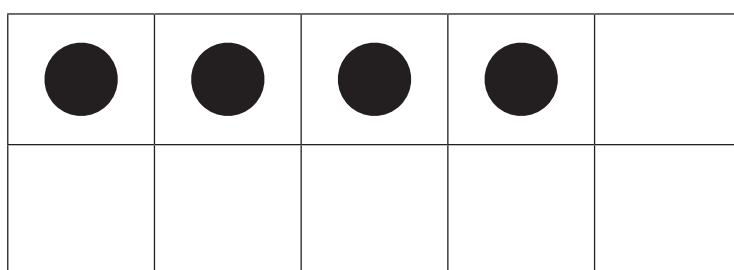
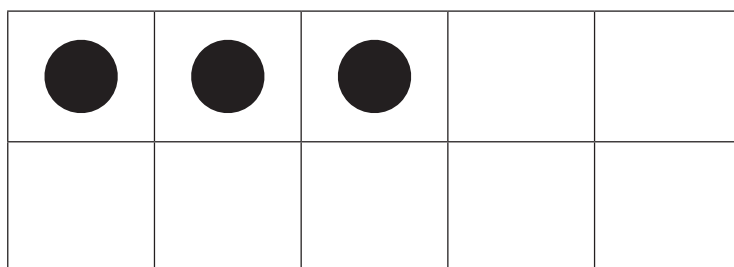
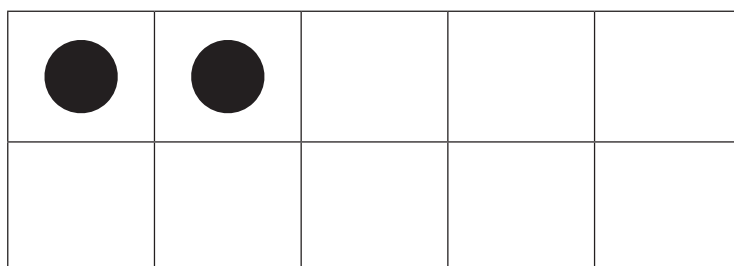
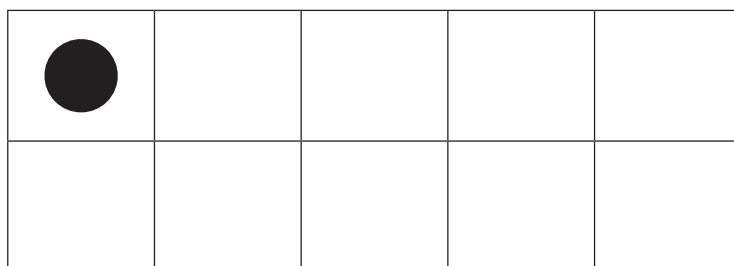



- (b) Number picture cards (ten frame cards)  
(Lesson 23 and others)

Garaṭa dza zwifanyiso zwa nomboro (garaṭa dza fureme ya mahumi) (Ngudo ya 23 na dziṅwe)

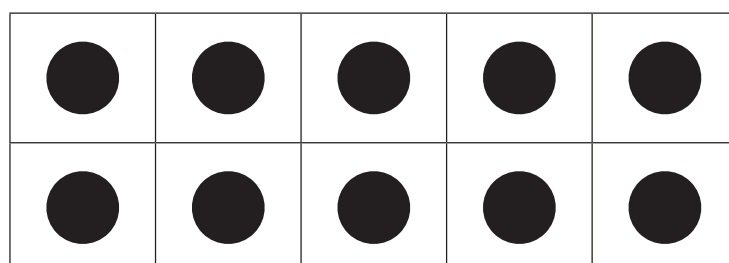
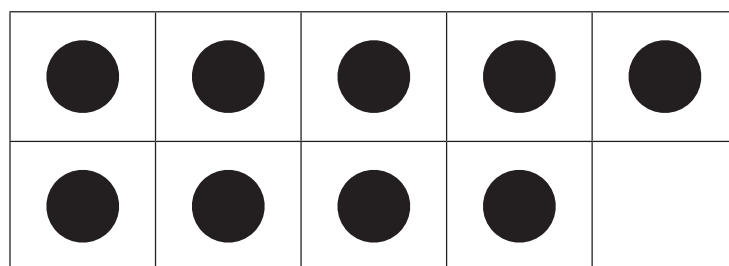
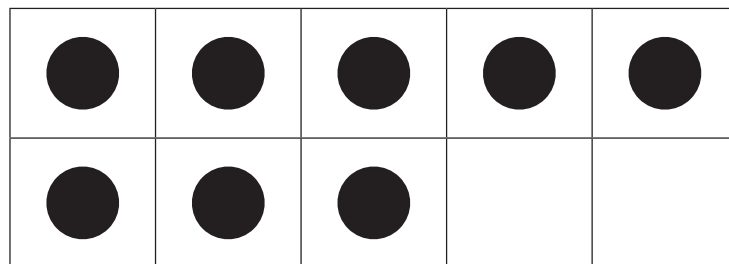
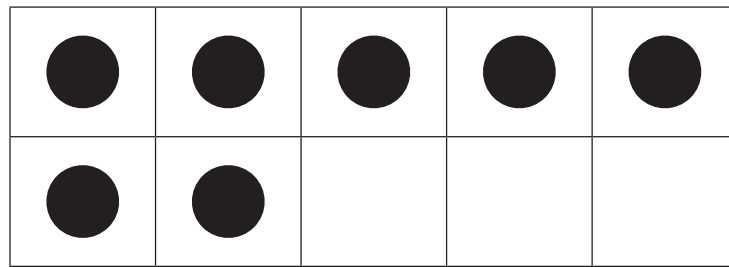
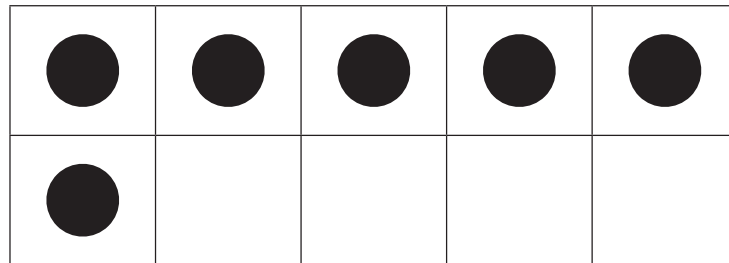



## Number cut outs (Lesson 26)

Zwigeriwa zwa nombororo (Ngudo ya 26)

1	2	3	4	5	6	7	8	9	10
---	---	---	---	---	---	---	---	---	----

1	2	3	4	5	6	7	8	9	10
1	2	3	4	5	6	7	8	9	10

1	2	3	4	5	6	7	8	9	10
---	---	---	---	---	---	---	---	---	----

1	2	3	4	5	6	7	8	9	10
1	2	3	4	5	6	7	8	9	10



Shape cut-outs (Lesson 43 and 48)

Zwigeriwa zwa zwivhumbeo (Ngudo ya 43 na ya 48)

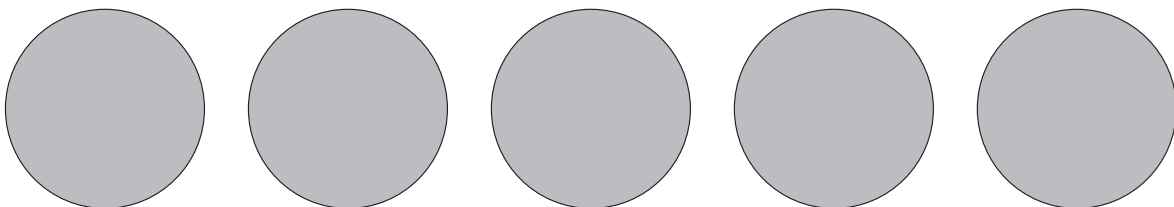
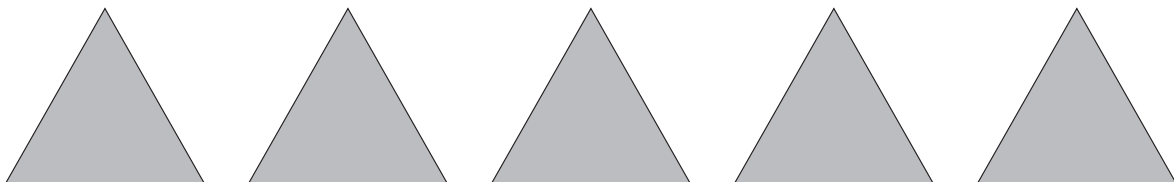
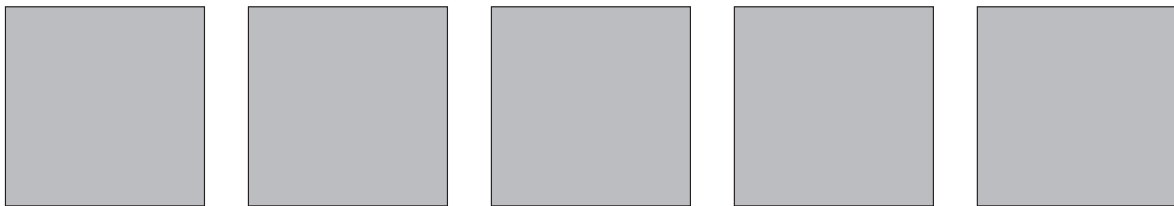
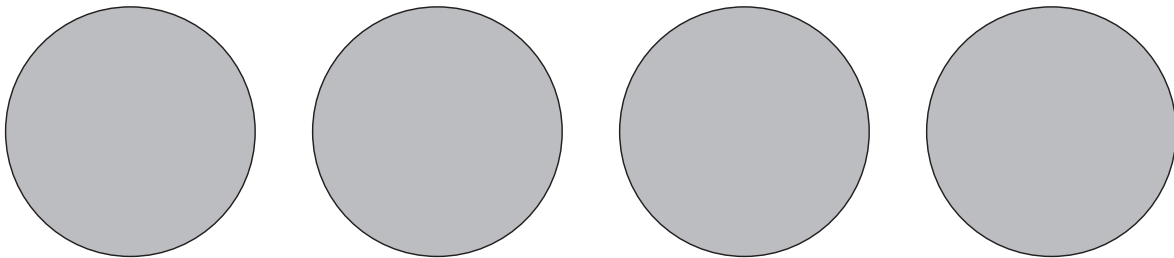
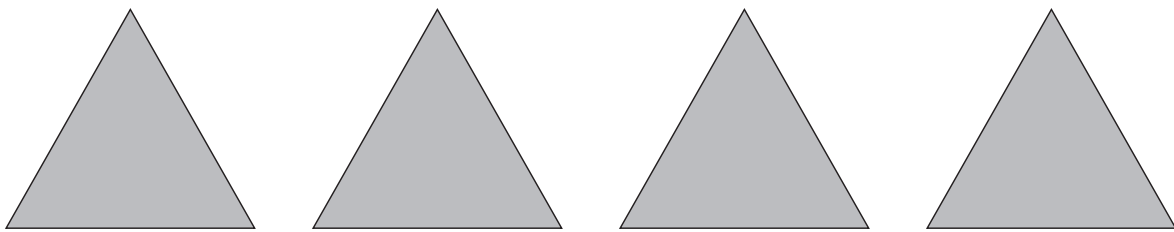
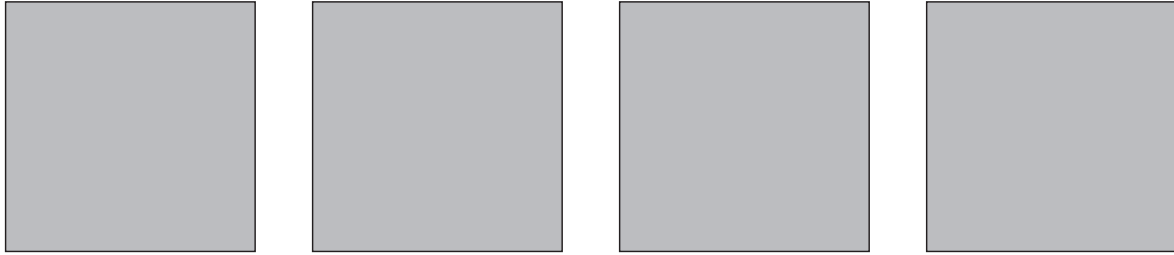



Pattern strips (Lesson 47)

Zwiṭiripi zwa/vhubambiri ha phetḥeni (Ngudo ya 47)

